

SL

XSL

Rigging manual

1.5 en

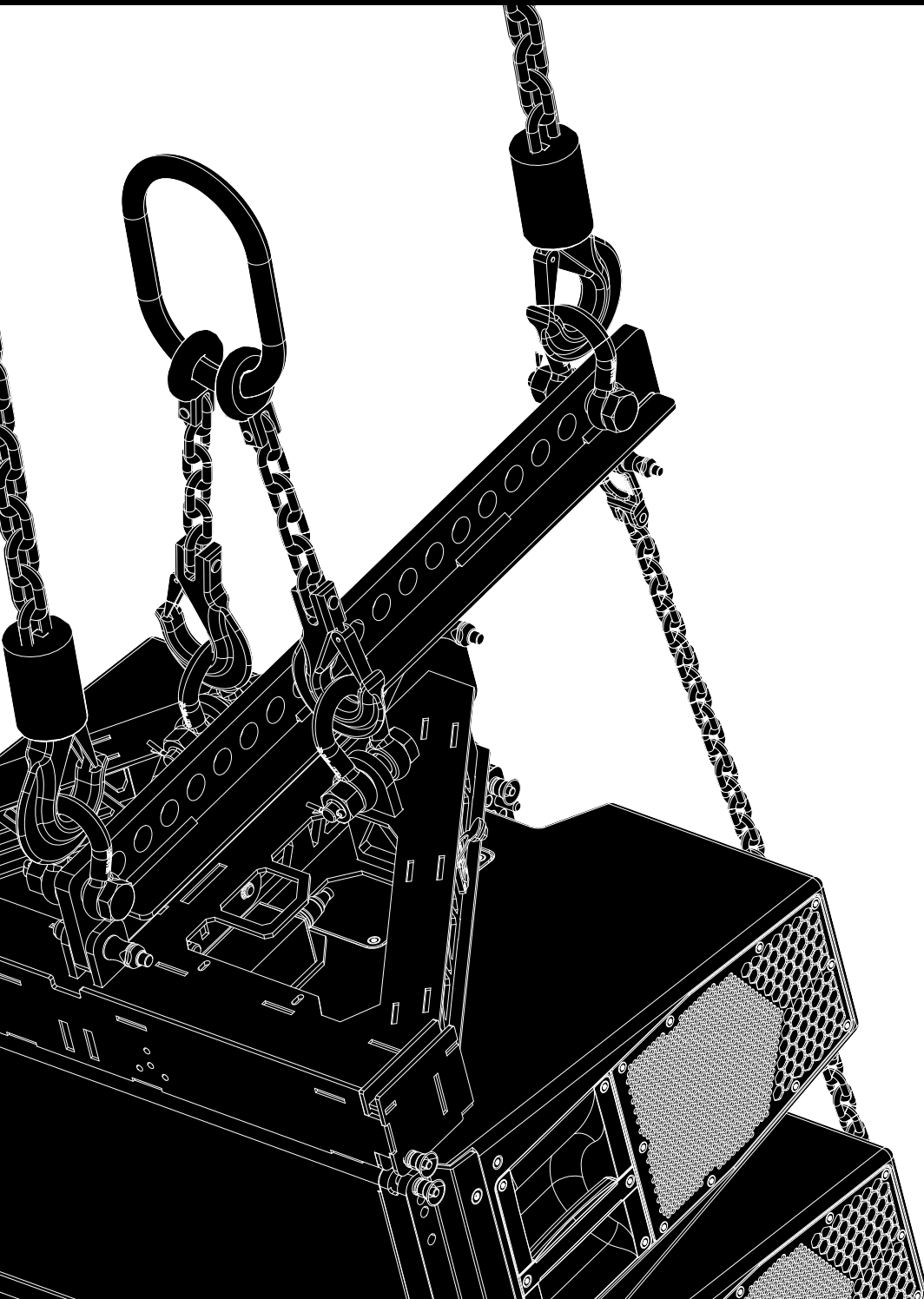

Notes on document version

All previous versions of this document are hereby no longer valid.

Version 1.5:

Z5770 XSL Flying frame set component list added.

Refer to:

.⇒ Chapter 3.1 "Z5770 XSL Flying frame set" on page 8.

General information

XSL Rigging manual

Version: 1.5 en, 11/2024, D2757.EN .01

Copyright © 2024 by d&b audiotechnik GmbH & Co. KG; all rights reserved.

Keep this document with the product or in a safe place so that it is available for future reference.

We recommend you to regularly check the d&b website for the latest version of this document.

When reselling this product, hand over this document to the new owner.

If you supply d&b products, please draw the attention of your customers to this document. Enclose the relevant documents with the systems. If you require additional documents for this purpose, you can order them from d&b.

d&b audiotechnik GmbH & Co. KG
Eugen-Adolff-Str. 134, D-71522 Backnang, Germany
T +49-7191-9669-0, F +49-7191-95 00 00
docadmin@dbaudio.com, www.dbaudio.com

1 Safety	4	10.2.2 Attaching the adapter frame.....	50
1.1 Intended use.....	4	10.2.3 Attaching the TOP cabinets.....	50
1.1.1 d&b ArrayCalc.....	4	11 XSL ground stack setups	52
1.2 General safety.....	4	11.1 XSL-SUB/XSL-GSUB ground stack.....	52
1.3 Components and weights/Load capacity.....	5	11.2 Mixed ground stack setup.....	52
1.3.1 Wind loads.....	5	11.2.1 XSL-SUB Adapter frame.....	52
1.4 Operational safety.....	5	11.2.2 Stack assembly.....	53
2 XSL rigging modes - 2 in 1	6	12 Safety and system checks	57
2.1 Rear rigging strand.....	6	12.1 Mechanical setup.....	57
3 XSL Rigging components	8	12.2 Wiring.....	57
3.1 Z5770 XSL Flying frame set.....	8	13 Hoisting, aiming and securing the array	58
3.2 Z5771 XSL Flying frame.....	8	13.1 Hoisting the array.....	58
3.3 Z5772 XSL Load beam.....	11	13.2 Aiming the array.....	58
3.3.1 Z5713 SL Cable pick.....	12	13.2.1 Horizontal aiming.....	59
3.4 Z5775 Safety chainset 2 t.....	13	13.2.2 Vertical aiming.....	59
3.5 Z5776 Hoist connector chain 2 t.....	13	13.3 Securing the array.....	60
3.6 Z5707 SL Aiming plate.....	14	14 Derigging	61
3.7 Z5774 XSL Compression frame.....	15	14.1 General.....	61
3.8 Z5773 XSL Compression set components.....	16	14.2 Compression mode disassembly.....	61
3.9 B2467.072 Crank lever hoist.....	17	14.3 Tension mode disassembly.....	62
3.9.1 Operation.....	17	15 Care and maintenance	63
3.10 Z5792 XSL Pullback frame.....	18	15.1 Transport / Storing.....	63
3.11 Z5783 XSL-SUB Adapter frame.....	19	15.2 etherCON connector socket protection.....	63
3.12 Locking pins.....	20	15.3 Visual and functional inspection.....	63
3.13 Ring cotters.....	21	16 Manufacturer's declarations	65
3.14 Suspension of the flying frame.....	22	16.1 Conformity of rigging components.....	65
3.14.1 Single pick point operation.....	22	16.2 Disposal.....	65
3.14.2 Dual pick point operation.....	22		
3.15 Secondary safety.....	23		
3.16 Cabinet rigging mechanism.....	23		
3.16.1 Front link mechanism.....	23		
3.16.2 Splay/Rear link mechanism.....	24		
3.17 XSL Touring carts.....	25		
3.17.1 E7809 Touring cart XSL8/XSL12.....	25		
3.17.2 E7812 Touring cart XSL-SUB.....	28		
4 XSL Array assemblies overview	30		
5 XSL Array assembly - Preassembly	31		
5.1 Setup preparation.....	31		
5.1.1 Attaching the Load beam to the Flying frame.....	31		
5.1.2 Connecting the d&b ArraySight sender unit.....	33		
6 Compression mode setup	34		
7 Tension mode setup	40		
8 XSL Pullback mode setup	44		
9 SUB columns	45		
9.1 Limitations.....	45		
9.2 Rear link of the flying frame.....	45		
9.3 SUB column setup.....	47		
10 Mixed array setup	49		
10.1 Remarks.....	49		
10.1.1 Rigging modes.....	49		
10.2 Order of assembly.....	49		
10.2.1 Suspending the desired number of SUB cabinets.....	49		

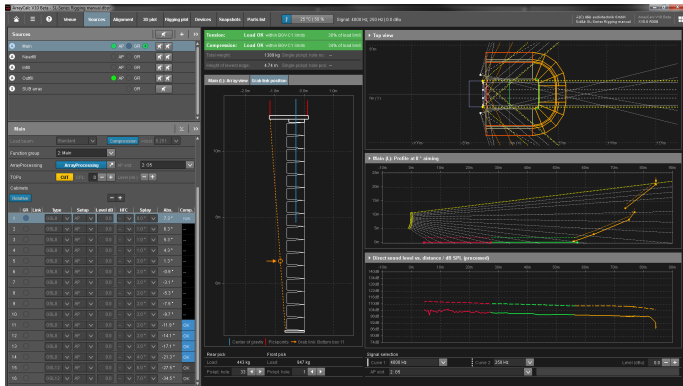

d&b ArrayCalc

1.1 Intended use

The XSL rigging components must only be used in conjunction with d&b XSL loudspeakers as described in this manual.

1.1.1 d&b ArrayCalc

For both safety and acoustic reasons, d&b line arrays must be designed using the d&b ArrayCalc simulation software. The software is available as a native stand-alone application for both Microsoft Windows and Mac OS X operating systems and can be downloaded at www.dbaudio.com.

Detailed information on how to use and operate ArrayCalc is provided by the Help system of the software. To access the Help system, press F1 or select the Help button () from the ArrayCalc toolbar. This will launch the HelpViewer which provides an overview of the program as well as a search function and direct access to the related topics.

In addition, ArrayCalc will provide you with typical array configurations within the permitted load limits and will help you get familiar with the mechanical load conditions and limitations.

d&b TI 385

Further information on line array design can be found in "TI 385 d&b Line array design, ArrayCalc". The TI is supplied with the software or can be downloaded from the d&b website at www.dbaudio.com.

d&b Seminar

We also recommend you to attend the regularly hosted d&b Line array training seminars. Further information regarding the d&b seminars and a seminar schedule can also be found on the d&b website at www.dbaudio.com.

d&b Video tutorials

In addition, d&b provides related video tutorials which can also be found on the d&b website at www.dbaudio.com or www.sl-series.com.

1.2 General safety

- Installation and setup should only be carried out by qualified and authorized personnel observing the valid national Rules for the Prevention of Accidents (RPA).
- It is the responsibility of the person installing the assembly to ensure that the suspension/fixing points are suitable for the intended use.
- Always carry out a visual and functional inspection of the items before use. In case there is any doubt as to the proper functioning and safety of the items, these must be withdrawn from use immediately.

Please also refer to ⇒ Chapter 15 "Care and maintenance" on page 63.

System components and weights

Loudspeaker

Z0770/Z0772 XSL8/XSL12 cabinets	39 kg (86 lb)
Z0774 XSL-SUB cabinet	66 kg (146 lb)

Rigging components

Z5771 XSL Flying frame	21 kg (46 lb)
Z5772 XSL Load beam	11 kg (24 lb)
Z5773 XSL Compression set	32 kg (70.5 lb)
.....including Z5774 XSL Compression frame (11 kg/24 lb)	
Z5707 SL Aiming plate	13.5 kg (29.8 lb)
Z5783 XSL-SUB Adapter frame	14 kg (31 lb)
Z5792 XSL Pullback frame	11 kg (24 lb)

1.3 Components and weights/Load capacity

Load capacity

NOTICE!

Z5771 XSL Flying frame

The Z5771 XSL Flying frame with the Z5772 XSL Load beam and the Z5707 SL Aiming plate is designed to support a total system weight of 1000 kg (2200 lb) - SWL including all rigging components.

Z5783 XSL-SUB Adapter frame

Together with the Z5771 XSL Flying frame the XSL-SUB Adapter frame allows the suspension of mixed array configurations consisting of XSL-TOP cabinets underneath XSL-SUB cabinets. However, observe the maximum total system weight of 1000 kg (2200 lb) - SWL including all rigging components, when setting up a mixed array configuration.

1.3.1 Wind loads



WARNING!

Potential risk of personal injury and material damage!

Flying loudspeakers overhead at wind forces higher than 6 bft (22-27 knots, 39-49 km/h, 25-31 mph) is not recommended.

If the wind force exceeds 8 bft (34-40 knots, 62-74 km/h, 39-46 mph):

- Make sure that no person remains in the vicinity of the array.
- Lower and secure the array.

1.4 Operational safety

- The assembly should always be carried out by two persons.
- During assembly, pay attention to the possible risk of crushing. Wear suitable protective clothing.
- Observe all instructions given on the respective instruction labels of the rigging components, such as load beams, flying and compression frames, touring carts, and loudspeaker cabinets.
- In connection with the d&b Z5711 ArraySight sender unit (laser inclinometer), take precautions to prevent anyone from looking directly into the laser beam, and wear appropriate eye protection.
- Be aware that any object or tool left on the top of the array during setup may fall when the array is operated. Always check that no tools or other objects are left on the array before final hoisting.
- When chain hoists are in operation, ensure that there is nobody directly underneath or in the vicinity of the load.
- Do not under any circumstances climb on the array.



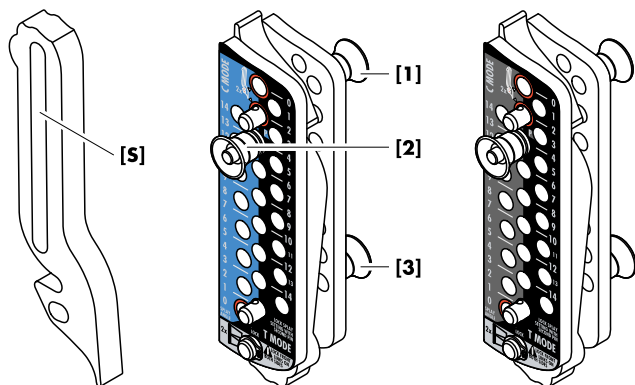

The XSL rigging system allows for two different rigging modes:

- **C MODE** ⇒ Compression mode,
- **T MODE** ⇒ Tension mode,
- or a combination of both, depending on the array length and the compression force required.

2.1 Rear rigging strand

Splay link, Locking pins and hole grids

The Splay link on the rear rigging strand of the XSL TOP cabinet is equipped with a slotted hole [S] which allows for either Compression or Tension mode setup without any further modification to the cabinet.

For this purpose, the rear rigging strand provides three Locking pins and three dedicated hole grids.

The bi-colored label (black/blue on XSL8 and black/grey on XSL12 cabinets) simplifies the assignment of the appropriate hole grid to the respective rigging mode.

The inner hole grid (colored area ⇒ **C MODE**) is used in Compression mode while the outer hole grid (black area ⇒ **T MODE**) is used in Tension mode.

The center hole grid applies to both rigging modes providing the odd splay angles in Compression mode and the even splay angles in Tension mode.

Locking pin conventions

Pin [1] Compression mode:

Pin [2] In Compression mode, pins [1] and [2] (Safety pin) are **always** inserted into the 0°/2° holes at the top of the center hole grid of all cabinets (⇒ Red labeled holes ○ - **C MODE**).

Tension mode:

In Tension mode, pin [1] is used to preset the splay angle (e.g. 2° as shown in the graphic opposite) of a certain cabinet on the center and outer hole grid of the cabinet itself. During hoisting, the Splay link of the upper cabinet will engage and safety pin [2] is inserted in the hole directly below.

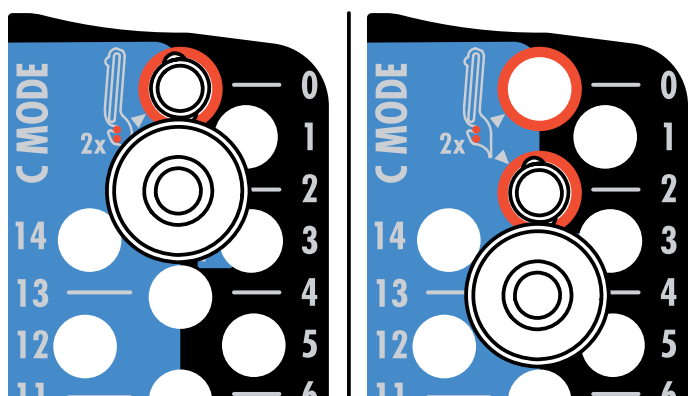

Pin [1]/[2] convention
Compression | Tension mode

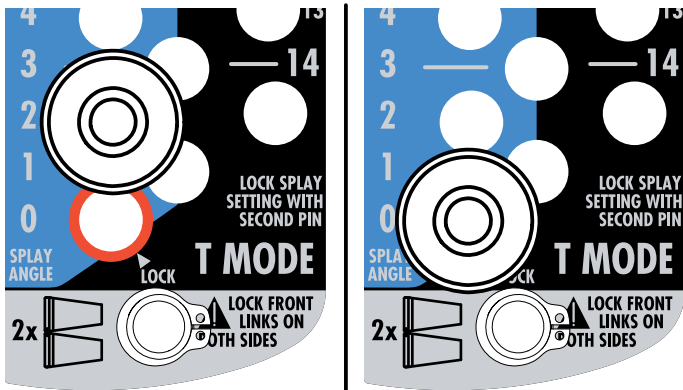

Pin [3] convention
Compression | Tension mode

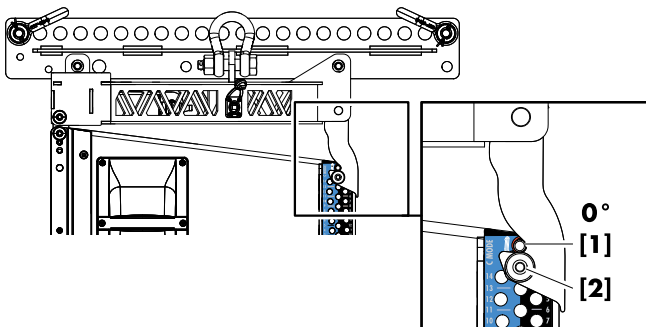
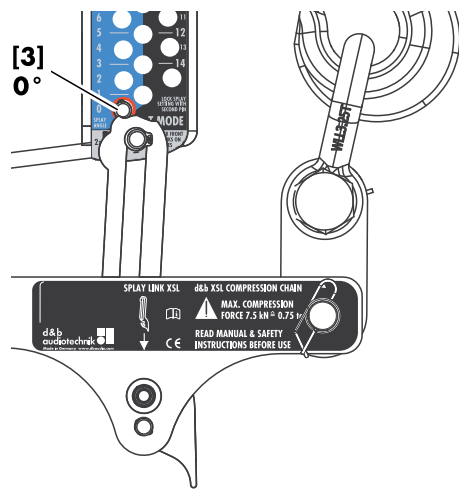

Pin [3] Compression mode:

In Compression mode, the splay angle between the cabinets (e.g. 2° as shown in the graphic opposite) is set on the rear rigging strand of the upper cabinet using pin [3].

Tension mode:

In Tension mode, pin [3] is **always** inserted in the 0° hole at the bottom of the inner hole grid to fix the Splay link in place (⇒ Red labeled hole **0° - T MODE**).

Pin [3] Compression frame:

In Compression mode the compression frame is attached below the last cabinet of the array. In this case, pin [3] is also **always** inserted in the 0° hole of the inner hole grid (⇒ Red labeled hole **0° - T MODE**).

First cabinet to frame

Due to the length of the frame's Splay link, for both, Compression and Tension modes, the Splay link of the frame is **always** engaged in the 0° hole at the top of the center hole grid of the first cabinet using pin [1] and safety pin [2] (⇒ Red labeled holes **0° - C MODE**).

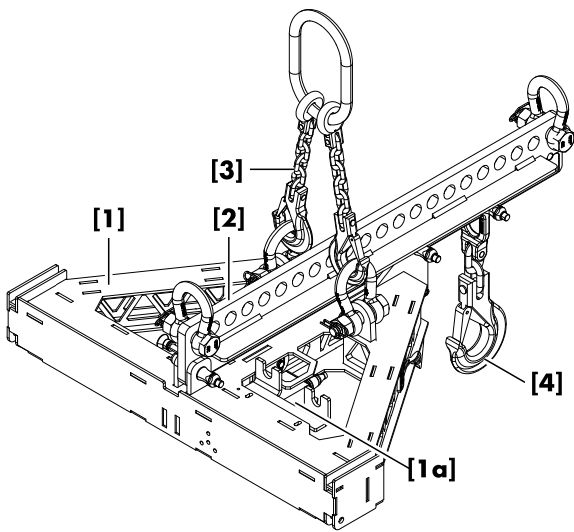

3.1 Z5770 XSL Flying frame set

The following, individual rigging components described in this section are included in the Z5770 XSL Flying frame set.

Please verify the shipment for completeness and proper condition of the items.

Z5770 XSL Flying frame set (42 kg/92.5 lb) - consisting of:

- **[1]** **Z5771** XSL Flying frame (21 kg/46 lb) including Z5711 **ArraySight** sender unit **[1a]** with enclosed shielded CAT5e 1:1 cable (K6006.200.00), 30 m (100 ft).
- **[2]** **Z5772** XSL Load beam (11 kg/24 lb).
- **[3]** **Z5775** Safety chain 2 t (3.2 kg/7 lb).
- **[4]** **Z5713** SL Cable pick (1.5 kg/3.3 lb).

3.2 Z5771 XSL Flying frame

The XSL Flying frame is equipped and supplied with the following rigging components:

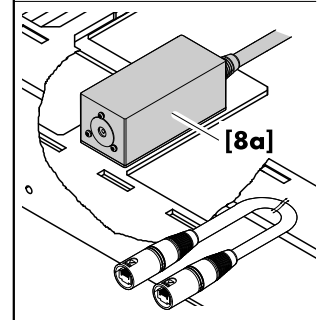
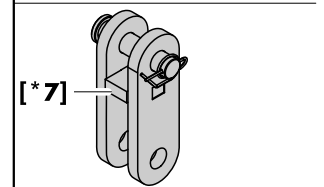
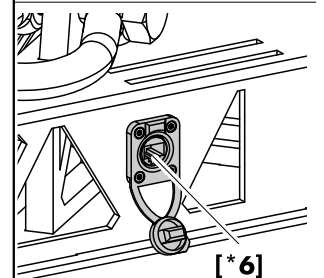
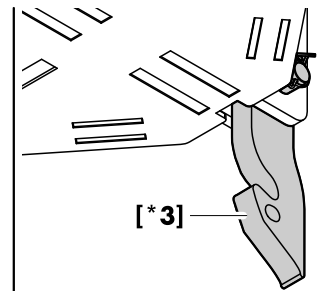
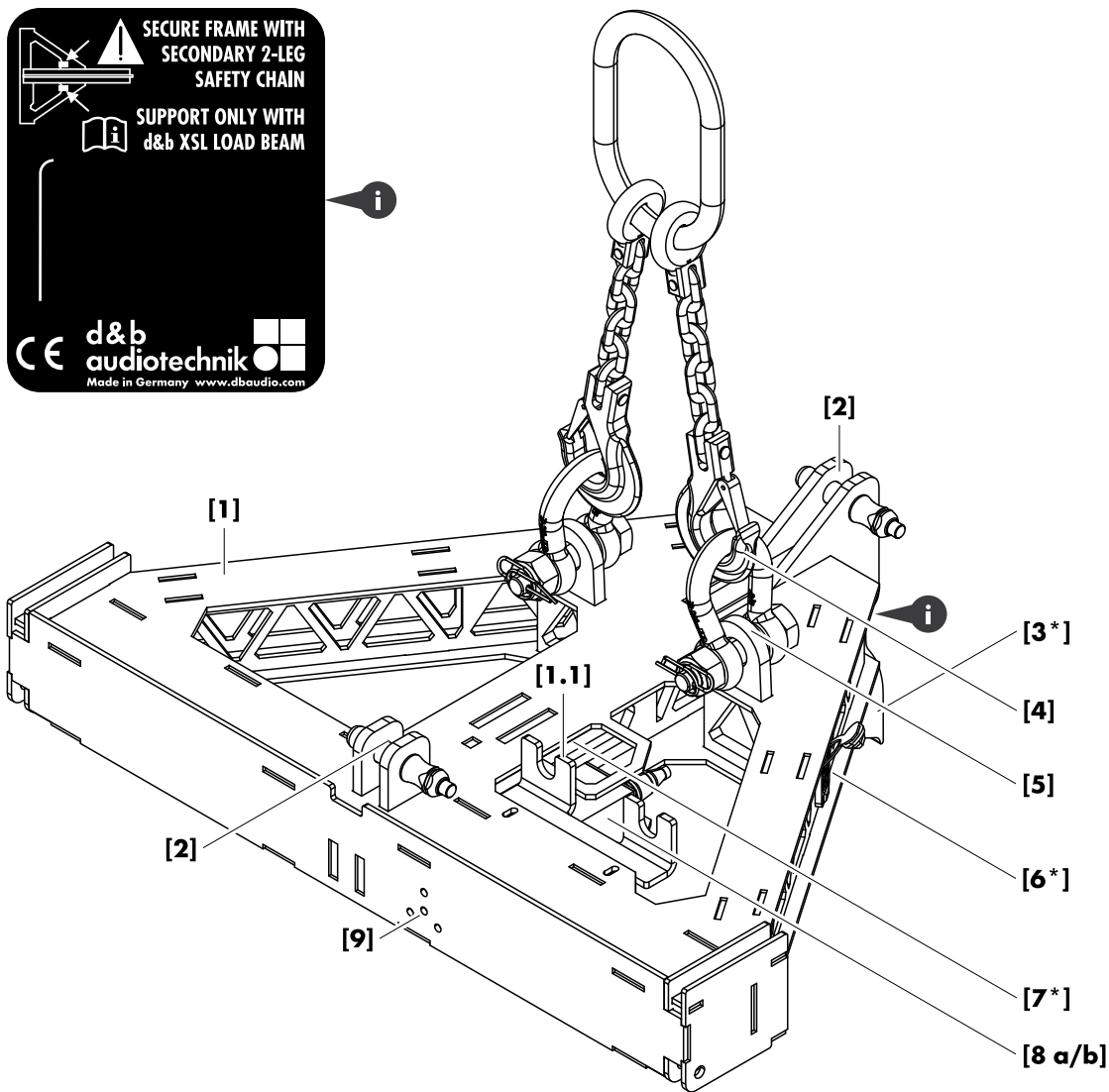

XSL Flying frame components:

Pos.	Component	Description
[1]	Z5771 XSL Flying frame	The XSL Flying frame is constructed from high-grade steel following the principles of truss construction to achieve the lowest possible dead weight of 21 kg (46 lb). It is designed to support arrays (columns) consisting of: XSL8, XSL12 and XSL-SUB loudspeakers with a total system weight of 1000 kg (2200 lb) - SWL. Either as pure TOP or SUB arrays or as mixed array configurations with SUB cabinets at the top of the array.
[1.1]	Parking slot for Z5772 XSL Load beam	In connection with the E7810 XSL Touring cart, the XSL Load beam is stored on top of the XSL Flying frame (refer to ⇒ Chapter 3.17.1 "E7809 Touring cart XSL8/XSL12" on page 25).
[2]		At the center front and rear of the frame, dedicated pick points and corresponding Locking pins (Type A: 16 x 40 mm) are provided to accept the respective load beam.
[*3]	Rear link (Frame)	The rear link of the frame are used to attach the first TOP cabinet to the frame.
[4]	Z5775 Safety chainset 2 t	The Z5775 Safety chainset 2 t is supplied with the corresponding Z5770 XSL Flying frame set.
[5]	Safety point(s)	The flying frame is fitted with two safety points, each equipped with a 3.25 t shackle to attach a secondary safety device using the enclosed Safety chain (refer to ⇒ Chapter 3.15 "Secondary safety" on page 23).
[*6]	etherCON connector socket	In connection with the d&b Z5711 ArraySight sender unit, the etherCON connector socket acts as a feed through to allow for easy connection of the sender unit.
[*7]	Rear link adapter	To attach the frame to SUB cabinets, the Rear link of the frame can be moved to the respective SUB position of the Load beam using the enclosed Rear link adapter, which provides the necessary extension length (refer to ⇒ Chapter 9.2 "Rear link of the flying frame" on page 45).
[*8a/8b]	Z5711 ArraySight sender unit	By factory default, the flying frame is equipped with a calibrated and adjusted d&b Z5711 ArraySight sender unit [8a] (laser inclinometer). An appropriate, shielded CAT5e 1:1 cable, 30 m (100 ft) is also provided (K6006.200.00 - [8b]) to allow either read out via the d&b Z5712 ArraySight meter unit (single operation) or via R1 in connection with the d&b Remote control network (remote operation - OCA/AES70). For detailed information on the d&b ArraySight inclinometer system, please refer to the ArraySight manual which is also supplied with the flying frame.
[9]		Four dedicated holes are provided at the front of the frame. The center hole serves as the exit for the laser beam, while the three surrounding holes allow for the adjustment of the ArraySight sender unit [8a] , if necessary.
i		Instruction label providing vital safety and rigging instructions.

Dimensional drawing

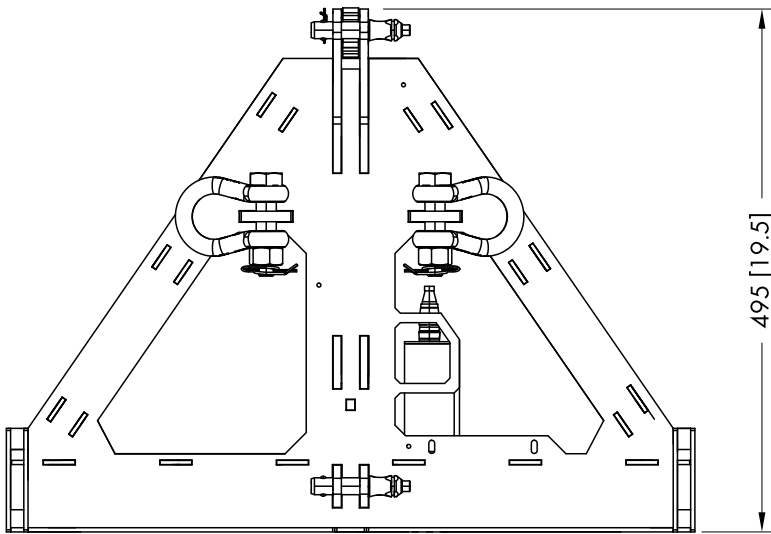
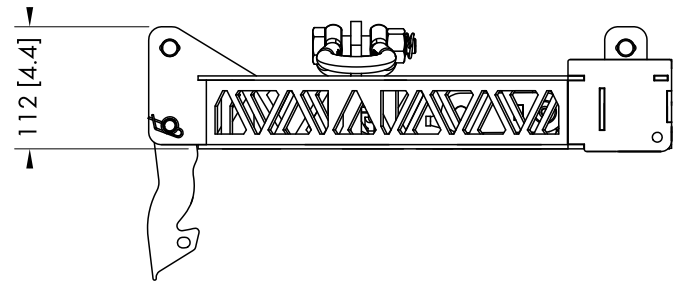
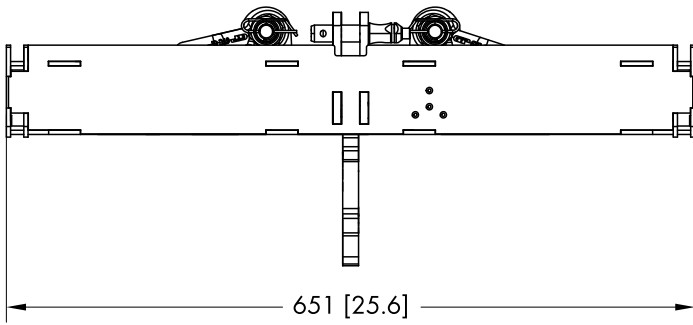

Z5771 XSL Flying frame dimensions in mm [inch]

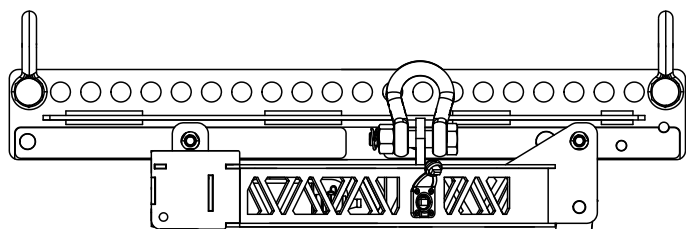
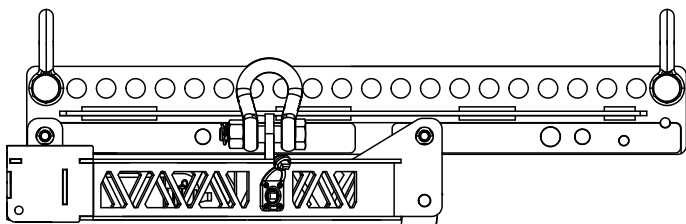
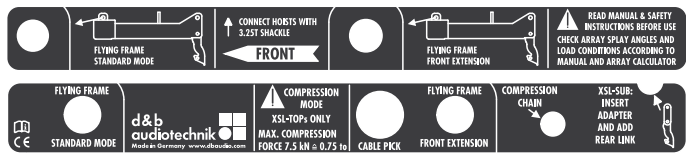
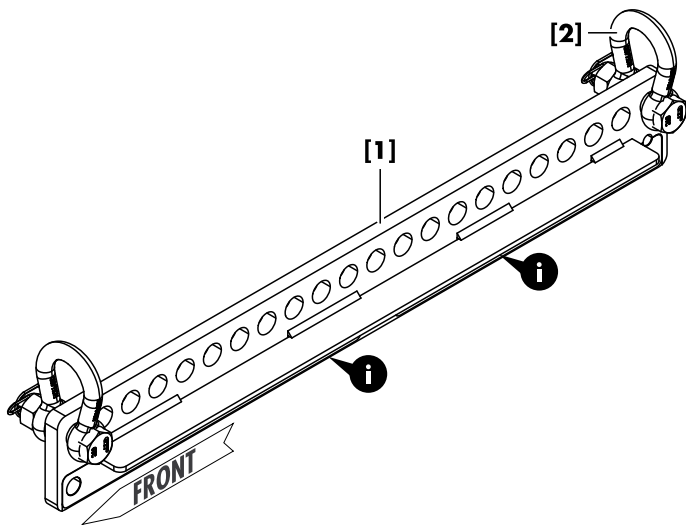

3.3 Z5772 XSL Load beam

The XSL load beam is equipped and supplied with the following rigging components:

Pos.	Component	Description
[1]	Z5772 XSL Load beam	The XSL Load beam is constructed from high-grade steel with a dead weight of 11 kg (24 lb). It is attached on top of the flying frame to allow either single or dual pickpoint operation. For this purpose, the load beam is equipped with a hole grid consisting of 22 holes with a diameter of 22 mm (0.85").
[2]		Two 3.25 t shackles are provided to allow direct connection to the chain hoist motor hook or to attach the Z5776 Hoist connector chain 2 t and/or the Z5707 SL Aiming plate.
i		Instruction labels providing vital safety and rigging instructions.

Load beam operating modes

The XSL Load beam allow for two operating modes:

STANDARD MODE

In standard mode, the load beam extends to the rear. This mode is used for standard array setup and allows for the required downtilt.

FRONT EXTENSION

In extension mode, the load beam extends to the front and allows for the required uptilt.

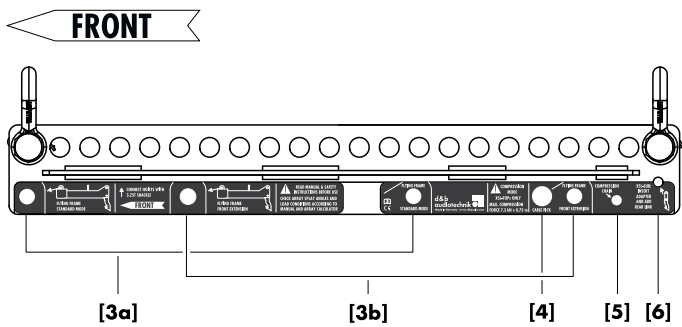

Load beam instruction label

Two instruction labels are located at the bottom strand of the load beams, indicating the hole positions for:

Pos.	Description
[3a/b]	Hole positions for the two rigging modes: <ul style="list-style-type: none"> ▪ Hole pair [3a] for STANDARD MODE. ▪ Hole pair [3b] for FRONT EXTENSION.
[4]	Hole position for the cable pick providing a 22 mm (0.85") hole for the attachment of a standard 3.25 t shackle.
[5]	Hole position for the attachment of the Z5789 XSL Compression chain.
[6]	Hole position for the additional Rear link adapter for the deployment of XSL-GSUB cabinets.

Dimensional drawing

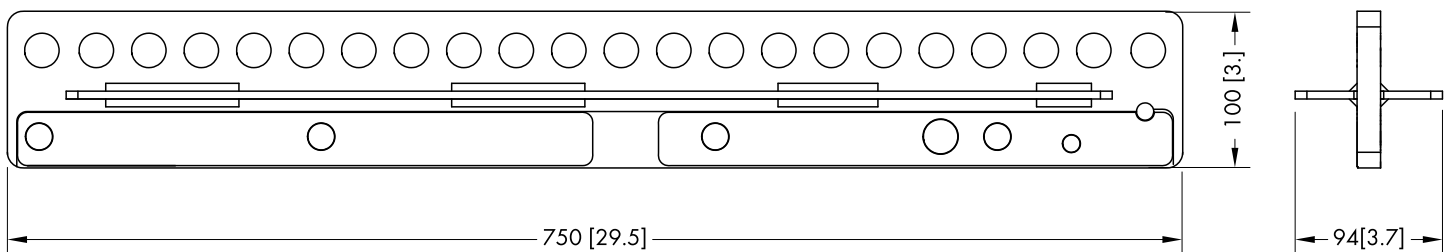

Z5772 XSL Load beam dimensions in mm [inch]

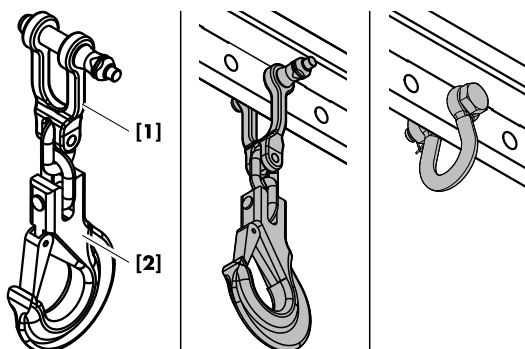

3.3.1 Z5713 SL Cable pick

The Z5713 SL Cable pick consists of coupling shackle **[1]** with a corresponding Locking pin (Type A: 16 x 55 mm) and a hook with safety latch **[2]**.

It is intended to be attached to the load beam. For this purpose, the load beam provides a dedicated 21 mm hole.

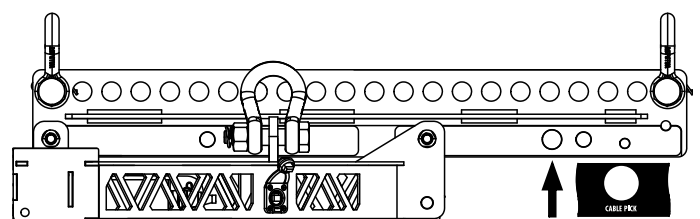

Alternatively, a standard 3.25 t shackle can be used for this purpose.

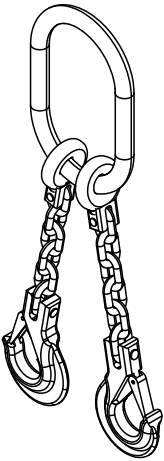

3.4 Z5775 Safety chainset 2 t

The Z5775 Safety chainset 2 t is supplied with the Flying frame and is used as a secondary safety device. Please also refer to ⇒ Chapter 13.3 "Securing the array" on page 60.

Specification

Lifting chain (DIN EN 818)	2-leg, 10 mm
Grade	8
Nominal length incl. hook	416 mm (16.4")
Load rating	2 t
Weight	3.2 kg/7 lb

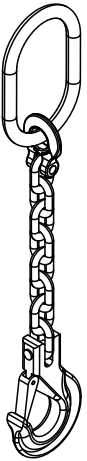

3.5 Z5776 Hoist connector chain 2 t

The Z5776 Hoist connector chain 2 t is used to connect the lifting motor(s) to the shackles of the load beam.

Its length of 535 mm (21") allows enough space for the hang of most 2 t motor chain containers and avoids any impact on the vertical balance of the array.

Specification

Lifting chain (DIN EN 818)	1-leg, 8 mm
Grade	8
Nominal length incl. hook	535 mm (21")
Load rating	2 t
Weight	2 kg/4.4 lb

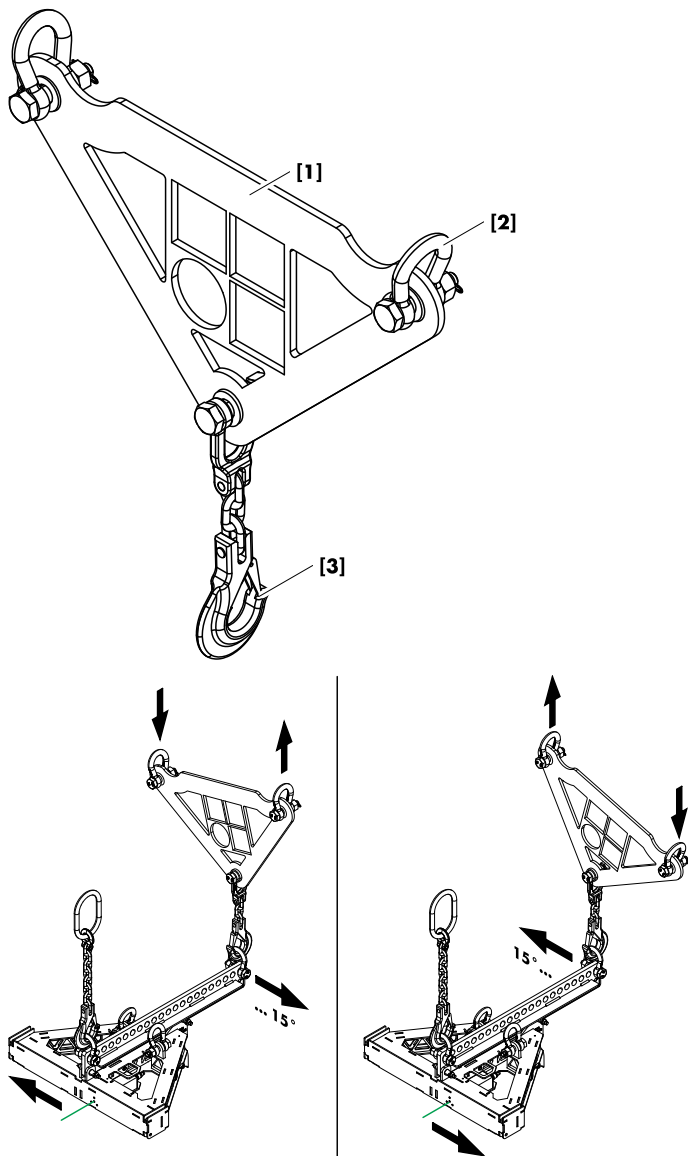

3.6 Z5707 SL Aiming plate

Please verify the shipment for completeness and proper condition of the items.

The Z5707 Aiming plate is equipped and supplied with the following rigging components:

Pos.	Component	Description
[1]	Z5707 SL Aiming plate	The Z5707 SL Aiming plate is constructed from high grade steel with a dead weight of 13.5 kg (29.8 lb). It is used for the horizontal aiming of an entire array using two motor hoists. With a chain hoist distance of minimum 0.6 m (2 ft), preferably approx 1 m (3 ft), the SL Aiming plate provides a horizontal angle range of $\pm 15^\circ$ (first and last pick holes of the load beam used).
[2]		Two 4.75 t shackles are provided to allow direct connection to the motor hoist hooks or to attach the Z5706 Hoist connector chain.
[3]		Load hook for attachment to the 4.75 t shackle of the corresponding SL-Series load beam or applicable d&b flying frame.

Dimensional drawing

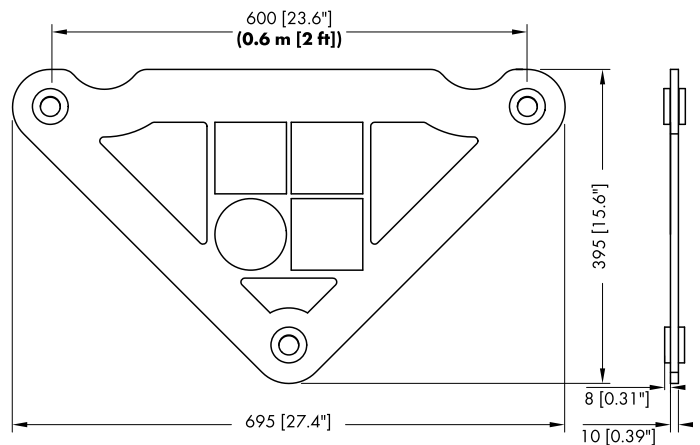

Z5707 SL Aiming plate dimensions in mm [inch]

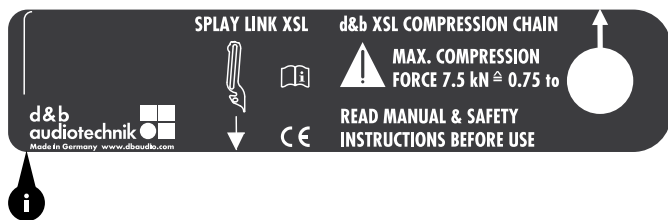
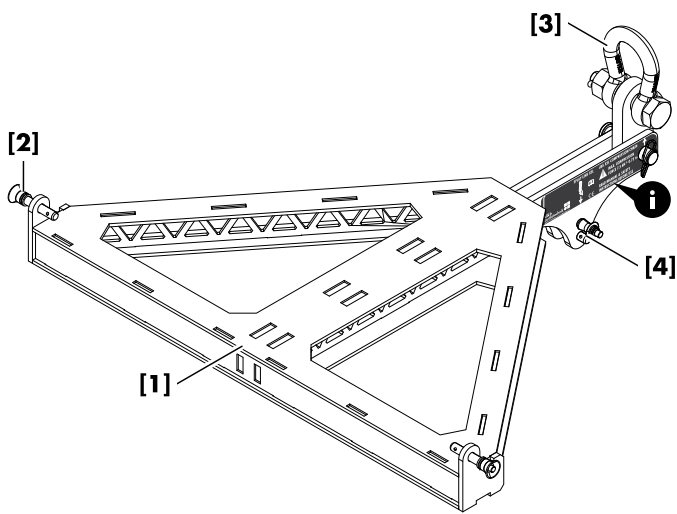

3.7 Z5774 XSL Compression frame

Please verify the shipment for completeness and proper condition of the items.

The XSL Compression frame is equipped and supplied with the following rigging components:

Pos.	Component	Description
[1]	Z5774 XSL Compression frame	The XSL compression frame is constructed from high-grade steel following the principles of truss construction to achieve the lowest possible dead weight of 11 kg (24 lb). It is attached to the bottom of the last cabinet of the array.
[2]	Locking pins front	Two Locking pins (Type C: 9 x 30 mm) are provided to attach the compression frame to the front rigging strands of the bottom cabinet.
[3]	Compression pickpoint	At the center rear, a dedicated pickpoint is provided to accept the Compression frame master link or the hook of a chain hoist. It comprises an O-ring and a dedicated 3.25 t shackle.
[4]	Splay link slot	A corresponding slot accepts the Splay link of the bottom cabinet which is fixed and secured using the two Locking pins (Type B: 9 x 40 mm).
i		Instruction labels providing vital safety and rigging instructions.

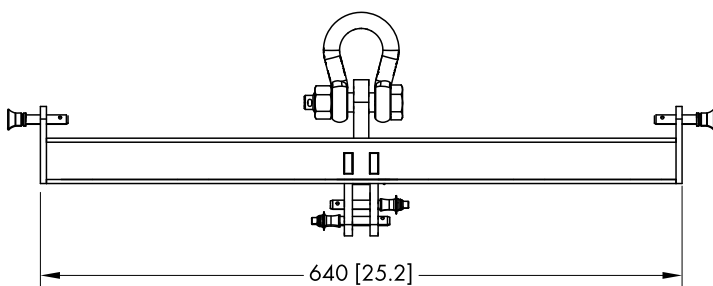

Z5774 XSL Compression frame dimensions in mm [inch]

Dimensional drawing

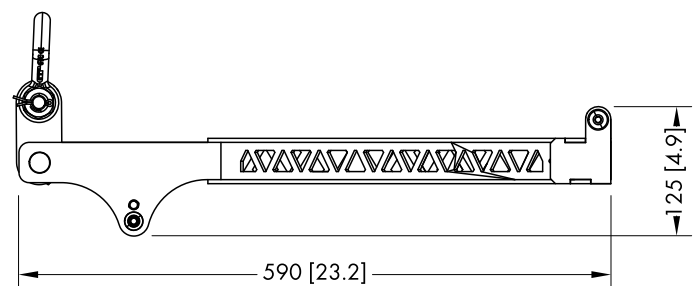

3.8 Z5773 XSL Compression set components

In addition to the XSL Compression frame, the compression set comprises the following components:

Pos.	Component and weight	Description
[2]	Z5789 XSL Compression chain 1.5t. (10 kg/22 lb)	The compression chain consists of a 7.5 m (25 ft)/6 mm chain (grade 10) and a coupling shackle with a corresponding Locking pin (Type D: 10 x 40 mm). The shackle allows direct attachment to the appropriate hole at the bottom rear of the corresponding load beam.
[3]	B2467.072 Crank lever hoist (6.7 kg/15 lb)	For XSL line arrays in Compression mode, the crank lever hoist is used to manually curve the array.
[4]	B2467.074 Compression frame master link (3.5 kg/7.7 lb)	For XSL line arrays in Compression mode, the compression frame master link is used to link the B2467.072 lever hoist to the rear pick point of the XSL Compression frame. The link itself consists of an O-ring, one chain leg including hook for attachment to the compression frame and a second chain leg with a corresponding grab link. Once the array is completely set up and curved, this second chain leg is used as secondary safety for the B2467.072 lever hoist and must be attached to the compression chain.
[5]	B2447.075 Chain bag (0.75 kg/1.65 lb)	Once the array is completely set up, the chain bag is used to store the remaining compression chain and lever hoist chain. For this purpose, the chain bag can be attached to the O-ring of the compression frame master link using the enclosed chain link with S-hook.

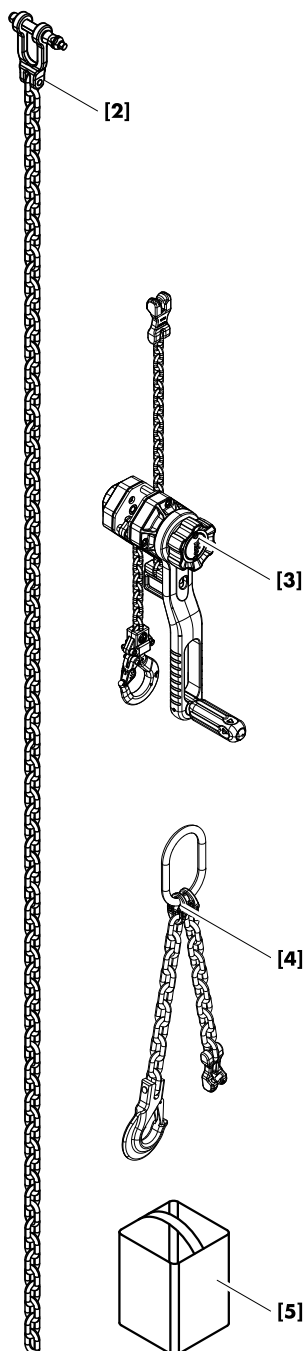

3.9 B2467.072 Crank lever hoist

With XSL line arrays in Compression mode, we recommend the use of the B2447.072 Crank lever hoist in connection with the d&b XSL Compression set to manually curve (compress) the array.

The lever hoist provides a compression force of up to 0.75 ton (7.5 kN) which corresponds to the maximum permitted compression force.

Apart from the gear housing, load chain and hook, the lever hoist consists of the following controls and indicators:

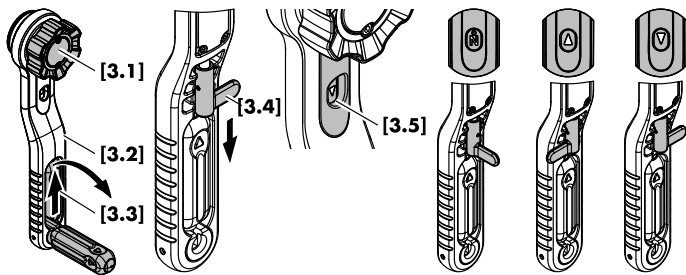

[3.1] Free chain knob

[3.2] Lever

[3.3] Pull-out crank:

1. Slightly lift the handle to unlock it.
2. Fold out the handle until it clicks into place.
3. To return the handle back to its upright position, simply pull the handle outwards and fold it back.

[3.4] Lever mode selector:

1. Pull down the lever to unlock it.
2. Turn it to the desired lever mode and release the lever.

The lever automatically snaps back into its lock position.

[3.5] Lever mode indicator:

N : **Neutral** - free chaining.

Δ : **Lifting** - clockwise.

∇ : **Lowering** - counter clockwise.

3.9.1 Operation

Free chaining operation

In free chaining mode, the brake is released and the load chain can be freely pulled through the hoist in either direction to its required length.

- ⇒ Set the lever mode selector **[3.4]** to the neutral (N) position.
 ↳ During free chaining operation, pull the chain slowly and continuously.

Load operation

Set the lever mode selector **[3.4]** to the desired position.

When operating the lever with the lever mode selector set to the lifting (Δ) or the lowering (∇) position, the hoist performs as follows:

- During lifting and lowering operations, braking is always applied.
- In lifting mode, the tightened mechanical brake supports the load on the pawls when the lever stops.
- In lowering mode, lever operation un-tightens the mechanical brake and lowers the load chain. When the lever stops, the mechanical brake is tightened again and supports the load instantly.

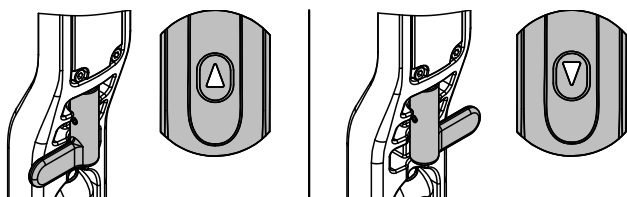
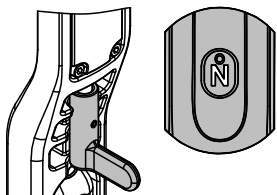

3.10 Z5792 XSL Pullback frame

Please verify the shipment for completeness and proper condition of the items.

The Z5792 XSL Pullback frame is equipped and supplied with the following rigging components:

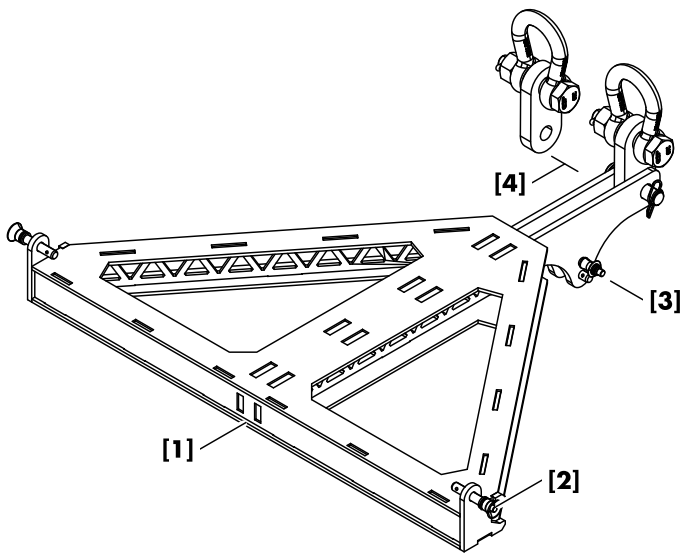

Pos.	Component	Description
[1]	Z5792	XSL Pullback frame (11 kg/24 lb).
[2]		Two Locking pins front (type C: 10 x 35 mm - stored in park position).
[3]		Two Locking pins rear (Type B: 10 x 45 mm).
[4]		2x Suspension device with corresponding 3.25 t shackle. One device is attached to the frame and is intended to connect the pullback chain hoist. The second device is intended to be attached to the rear pick point of the XSL Flying frame to connect the chain hoist.

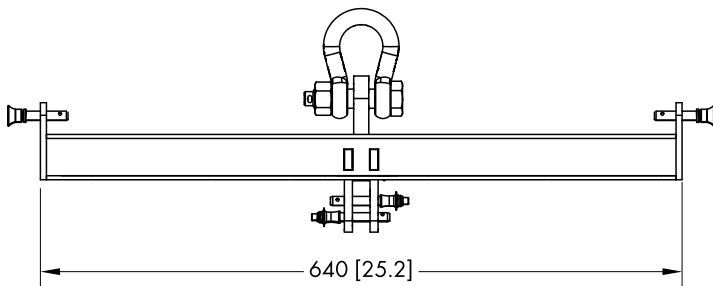

Z5792 XSL Pullback frame dimensions in mm [inch]

Dimensional drawing

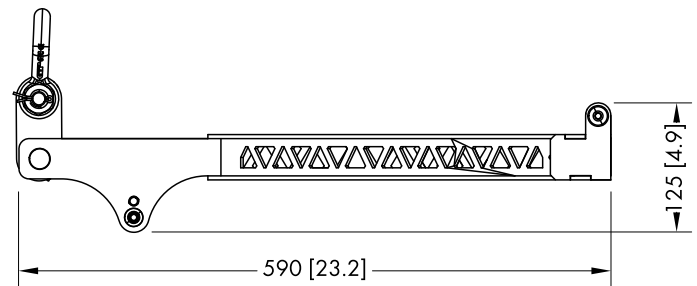

3.11 Z5783 XSL-SUB Adapter frame

Intended use

The Z5783 XSL-SUB Adapter frame is used to suspend mixed array configurations consisting of XSL-TOP cabinets underneath XSL-SUB cabinets (⇒ **FLYING MODE** labeling).

It is also used for ground stack setups to deploy XSL-TOP cabinets on top of XSL-SUB cabinets (⇒ **STACKING MODE** labeling).

Scope of supply

Please verify the shipment for completeness and proper condition of the items.

The Z5783 XSL-SUB Adapter frame is equipped and supplied with the following rigging components:

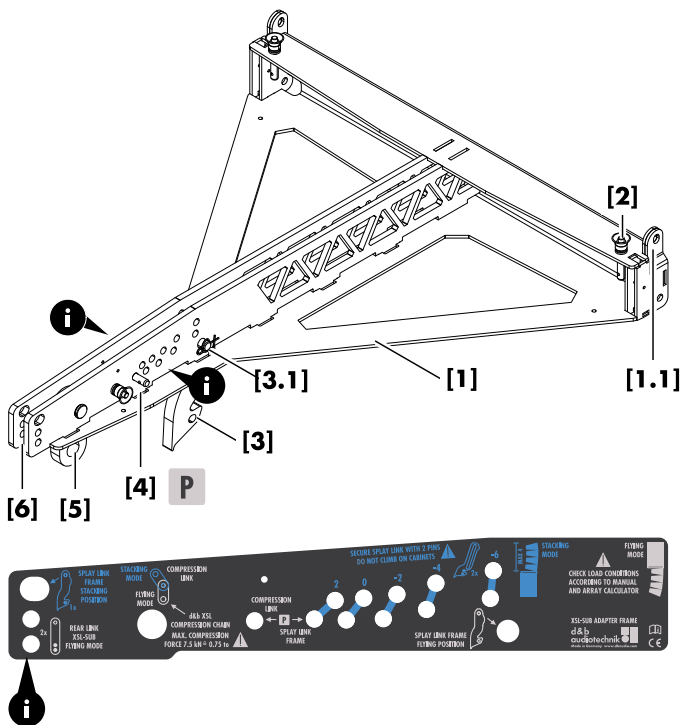

Pos.	Component	Description
[1]	Z5783	XSL-SUB Adapter frame (14 kg/31 lb).
[1.1]	Front links	The front tie bar of the adapter is equipped with fixed Front links.
[2]	Locking pins	Locking pins (shown in their park position).
[3]	Splay link	Splay link including fixing bolt [3.1]. In combination with the Front links of the XSL-TOP cabinets, the Splay link of the frame is used to attach the first TOP cabinet underneath XSL-SUB cabinets.
[4]	Locking pins	Two Locking pins, holding the Splay link and the Compression link in their park position (⇒ P). These Locking pins are also used to fix the Splay link of the bottom XSL-SUB cabinet to the adapter frame in a mixed array configuration.
[5]	Compression link	Compression link for the attachment of the XSL Compression chain.
[6]	Rear link slot	In 'FLYING MODE' setup, the slot is used to fix the Rear link of the XSL-SUB cabinet (refer to ⇒ Chapter 10.2.2 "Attaching the adapter frame" on page 50). In 'STACKING MODE' setup, the slot is used to fix the Splay link of the adapter frame (refer to ⇒ Chapter 11.2.1 "XSL-SUB Adapter frame" on page 52).
[i]		Instruction label providing vital safety and rigging instructions.

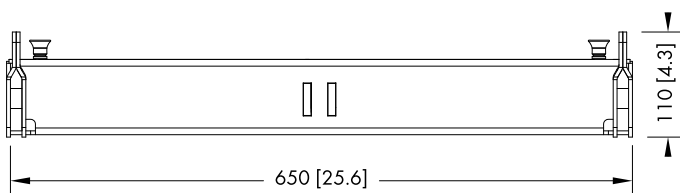

Z5783 XSL-SUB Adapter frame dimensions in mm [inch]

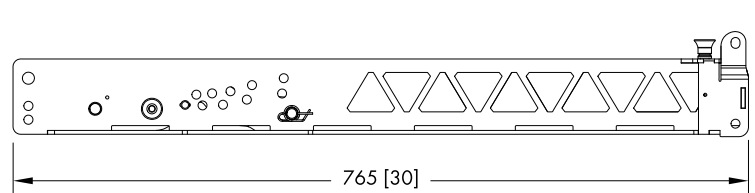

3.12 Locking pins



WARNING!

Potential risk of personal injury and/or damage to material!

The steel wires between the Locking pins of the cabinets and rigging components are not intended to carry any load. The cabinet's weight must only be carried by the Front and Splay/Rear links in connection with the front and rear rigging strands of the loudspeaker cabinets and the Flying frame.

Please observe the following:

- The steel wire must run from the upper to the lower Locking pin.
- Do not cross the Locking pins to avoid twisting of the steel wires.
- Ensure all Locking pins are fully inserted and securely locked before lifting any load by briefly pulling the Locking pin towards you.

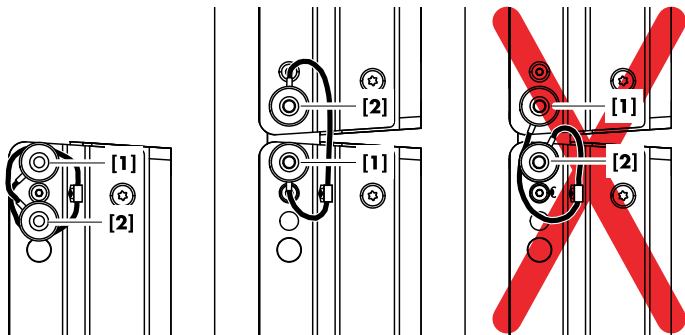

The XSL loudspeaker cabinets, frames, and touring carts are equipped with three types of Locking pins:

- [A]** Locking pin 16 x 40 mm.
Used for the flying frame and the coupling shackle of the compression chain.
- [B]** Locking pin 9 x 40 mm for TOP and SUB cabinets.
- [C]** Locking pin 9 x 30 mm.
Used for the Front links of the loudspeaker cabinets, the compression frames' and the touring carts' front supports.
- [D]** Locking pin 10 x 40 mm.
Used for the Rear link adapter and Splay/Rear link slots of the touring carts.

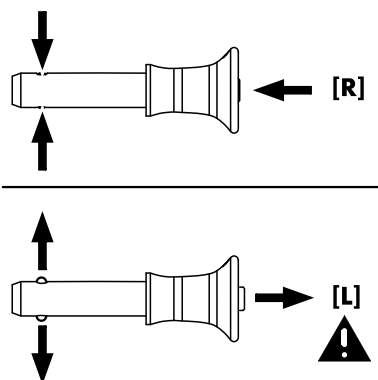
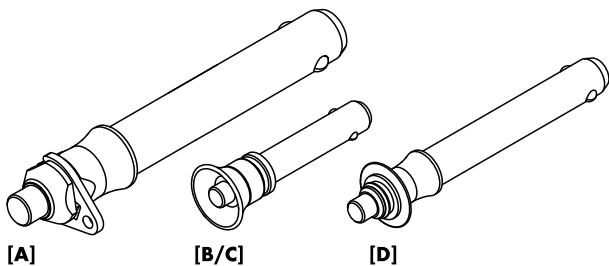

Locking pin functionality
Shown with pin type [C]

Functionality (Quick lock mechanism)

The quick lock mechanism applies to all types of Locking pins listed above. Proceed as follows:

1. Press the button to **Release** the locking mechanism (← [R]).
2. Remove the Locking pin through the respective link or socket.
3. Insert the Locking pin through the respective link or socket until it is fixed in place.
4. Release the button to **Lock** the pin (→ [L]).
5. Recheck the Locking pin is securely locked by briefly pulling the Locking pin towards you.

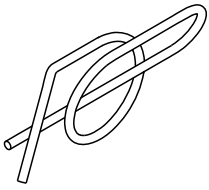

Ring cotter

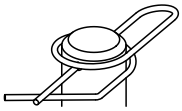

Ring cotter locked

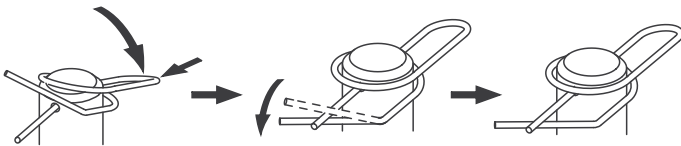
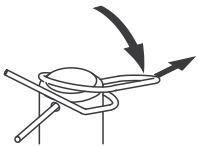
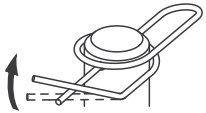

3.13 Ring cotters

In connection with the SL-Series rigging system, ring cotters are used for the following items to prevent the respective item from slackening and/or loosening:

- Fixing bolt of the shackles attached to the Load beam and safety points of the Flying frame.
- Fixing bolt of the Flying frame's Rear link and Rear link adapter.
- Fixing bolt of the shackle attached to the Compression frame.
- Fixing bolt of the shackles attached to the Aiming plate.

Function of the ring cotter

By default, the ring cotters are "locked" to prevent them from loosening.

For modification reasons such as altering a position or exchanging a rigging component, it may be necessary to temporarily remove the ring cotter and reattach it afterwards.

Note: Please also refer to ⇒ Chapter 15 "Care and maintenance" on page 63.

For this purpose, proceed as follows:

1. **Unlock**
Unlock the ring cotter by pushing up the front wire loop over the straight wire shaft.
2. **Release and remove**
Push down the rear wire loop until the ring cotter snaps over the edge of the bolt and remove the ring cotter.
3. **Refit and lock**
Refit the ring cotter by pushing the straight wire shaft through the hole and pressing the front wire loop underneath the straight wire shaft.

3.14 Suspension of the flying frame

The suspension of the XSL Flying frame is carried out using the XSL Load beam. The Load beam allows for either Single or Dual pickpoint operation. For this purpose, the Load beam is equipped with 22 mm holes that accept the enclosed 3.25 t shackles.

3.14.1 Single pick point operation

NOTICE!

Single pick point operation is not recommended for Compression mode.

With "Single pick point operation" the position of the shackle defines the vertical aiming of the entire array.

The corresponding hole position (one hole detent) is calculated using ArrayCalc.

Note: The target angle of the entire array is achieved when the array is fully set up, hoisted, and secured as intended.

Attachment

1. Choose the appropriate hole position on the Load beam according to the ArrayCalc calculation and attach the shackle correspondingly.
2. Attach the hoist connector chain or motor hook to the shackle of the Load beam respectively.

3.14.2 Dual pick point operation

With "Dual pick point operation" the vertical aiming of the array is set by trimming the hoist motors after the array has been fully assembled and lifted to its operating position.

The corresponding hole positions are selected according to ArrayCalc.

Attachment

1. Choose the appropriate hole positions for the front and rear pick on the Load beam according to ArrayCalc and attach the enclosed shackles correspondingly.
2. Connect the hoist connector chain, aiming plate and/or motor hooks to the shackles of the Load beam, respectively.

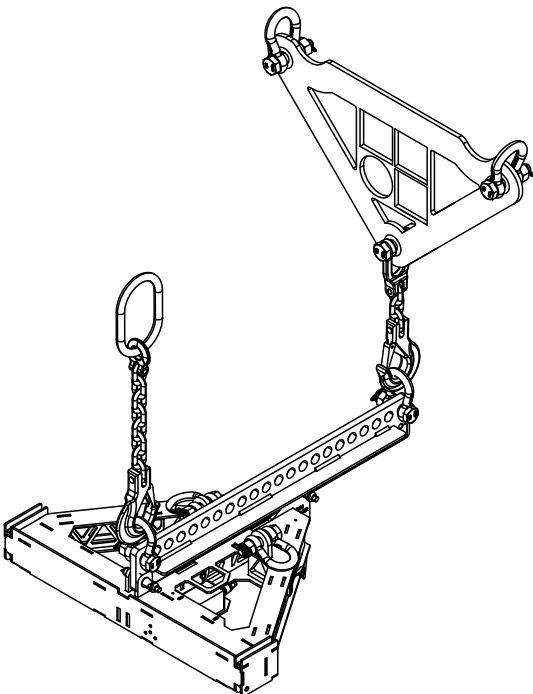
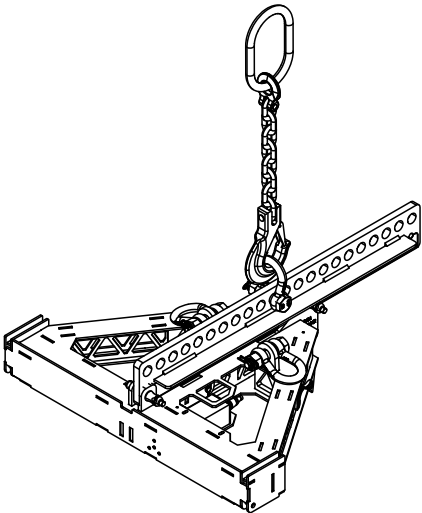

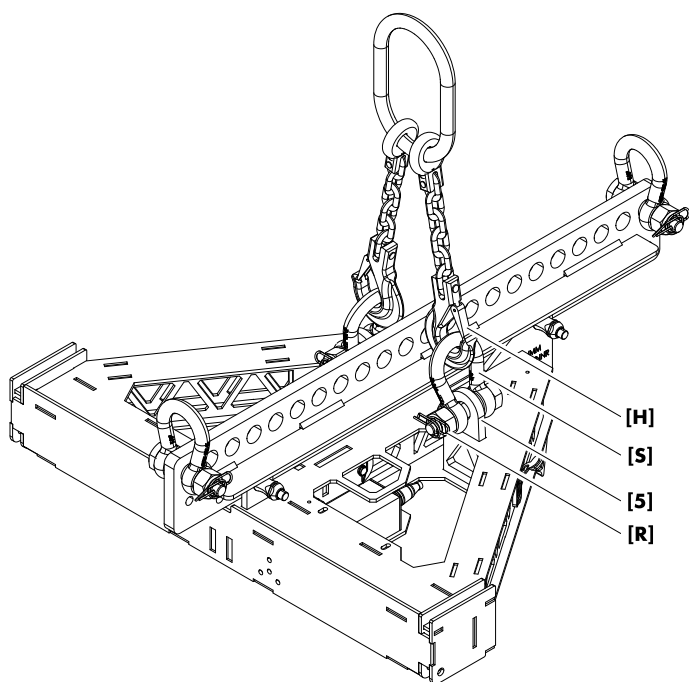

3.15 Secondary safety

The XSL Flying frame is equipped with two safety points [5] fitted with two 3.25 t shackles to accept a secondary safety device. For this purpose, use the d&b Z5775 Safety chainset 2 t which is supplied with the flying frame or an appropriate equivalent according to the specifications which are defined in ⇒ Chapter 3.4 "Z5775 Safety chainset 2 t" on page 13.

Assembly

1. Before attaching the safety device, ensure the two 3.25 t shackles [S] are properly fitted to the frame's safety points [5] and secured against loosening using a locked ring cotter [R], as shown in the graphic opposite.
2. Attach the safety chain set and ensure the chains are not twisted and the hooks [H] are in the right direction, as shown in the graphic opposite.

3.16 Cabinet rigging mechanism

The cabinets are mechanically connected to the Flying frame and subsequent loudspeakers using the Front links attached to both sides of the cabinet front and the central Splay/Rear link at the rear of the cabinet.

All necessary rigging components are mounted to the cabinet and slide out when needed.

In principle, the Front link mechanism applies to both the TOP and SUB cabinets. The Front links are spring loaded and therefore extend automatically as soon as the respective Locking pins are released and pulled out.

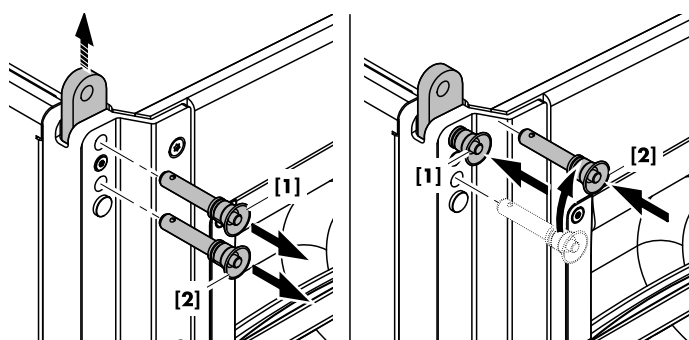

3.16.1 Front link mechanism

TOP cabinets

1. Release the bottom Locking pin [2].
2. Release the upper Locking pin [1].
 - ↳ The Front link extends automatically.
3. Reinsert and lock Locking pin [1] to fix the Front link in place.
 - ↳ Locking pin [2] is inserted to the upper cabinet.

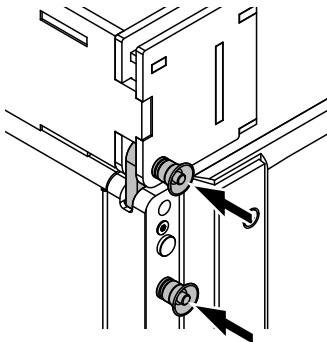
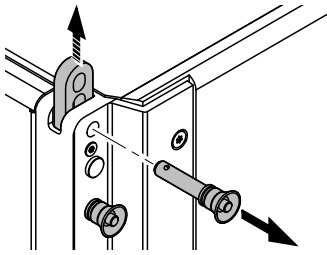

Fig. 1: SUB to Frame

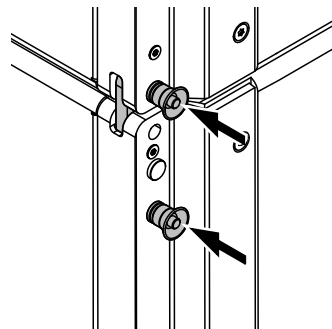

Fig. 2: SUB to SUB 0° splay

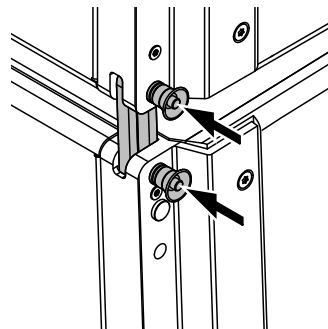

Fig. 3: SUB to SUB 2° splay, free

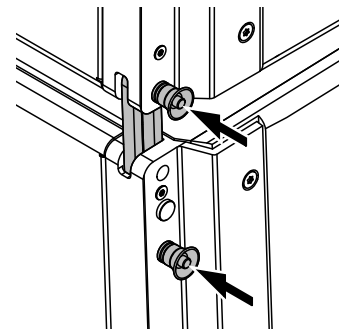

Fig. 4: SUB to SUB 2° splay, blocked

SUB cabinets

- ⇒ Release the upper Locking pin.
- ↳ The Front link extends automatically.

The Front link mechanism of the SUB cabinets provides four different settings:

1. SUB to Frame (⇒ Fig. 1).
 2. SUB to SUB with 0° splay between the cabinets (⇒ Fig. 2).
 3. SUB to SUB with 2° splay (free) between the cabinets (⇒ Fig. 3).
 4. SUB to SUB with 2° splay (blocked) between the cabinets (⇒ Fig. 4).
- This setting is used to prevent the cabinets from folding up.

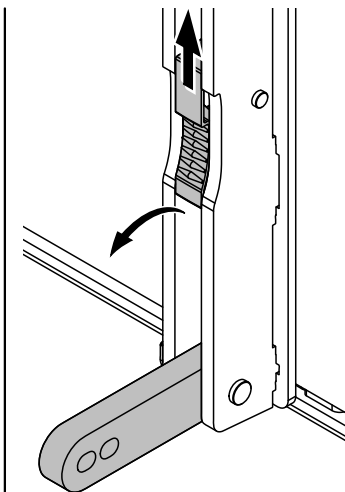
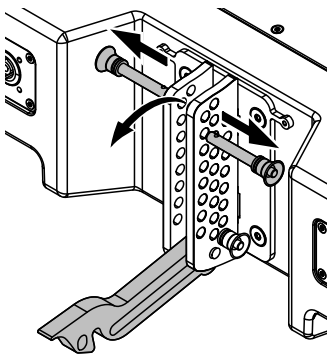

TOP | SUB

3.16.2 Splay/Rear link mechanism

TOP cabinets

On TOP cabinets release the respective Locking pins and fold out the Splay link.

SUB cabinets

The Rear link of the SUB cabinets is fixed in its park position by a spring loaded slider mechanism.

To release the link simply push the slider upwards.

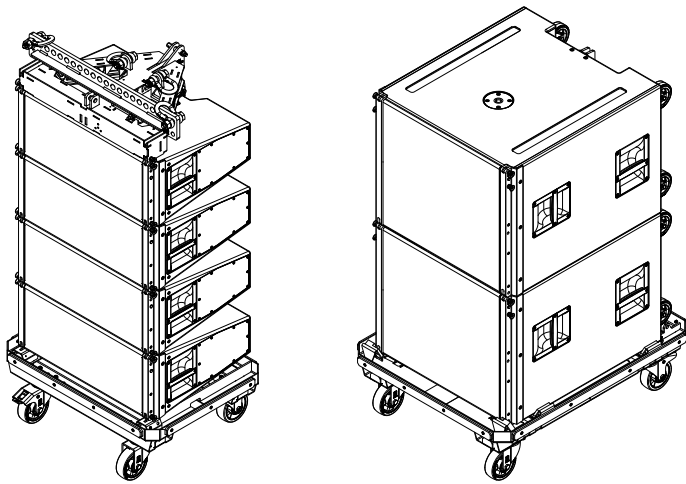

3.17 XSL Touring carts

Intended use

The d&b XSL Touring carts are an integrated part of the XSL rigging system. They are intended as transport solution as well as for setup, requiring less space on-site.

In addition, the Load beam can also be stored in the cart, while the Flying frame may be mounted and remain on top of the entire cabinet assembly during transport and storage in the cart.

Once the cabinet assemblies are suspended, the touring carts can be stacked and stored away.

The XSL-SUB Touring carts are also intended as ground support for XSL-SUB ground stacks. Please refer to ⇒ Chapter 11 “XSL ground stack setups” on page 52.

The XSL Touring carts are equipped and supplied with the following rigging components.

Please verify the shipment for completeness and proper condition of the items.

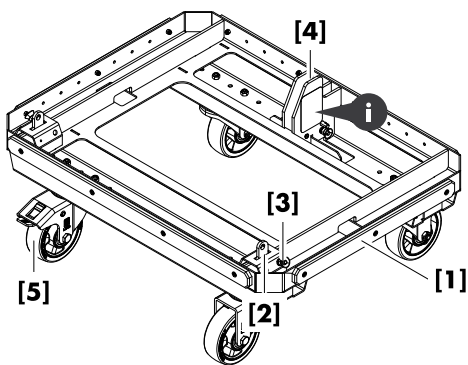

3.17.1 E7809 Touring cart XSL8/XSL12

Pos.	Component	Description
[1]	E7809	Touring cart 4 x XSL8/XSL12 Total weight: 220 kg (485 lb), incl. Flying frame and Load beam. Dimensions: H x W x D (cm) 160 x 80 x 60 H x W x D (inch) 63 x 31.5 x 24
[2]		Dedicated supports at the front left and right.
[3]		2 x Locking pins at the front left and right in park position.
[4]		Splay link slot incl. 2 x Locking pins.
[5]		Four heavy duty wheels 125 x 40 mm, two of them as brake wheels.
i		Touring cart instruction label providing vital safety and rigging instructions.

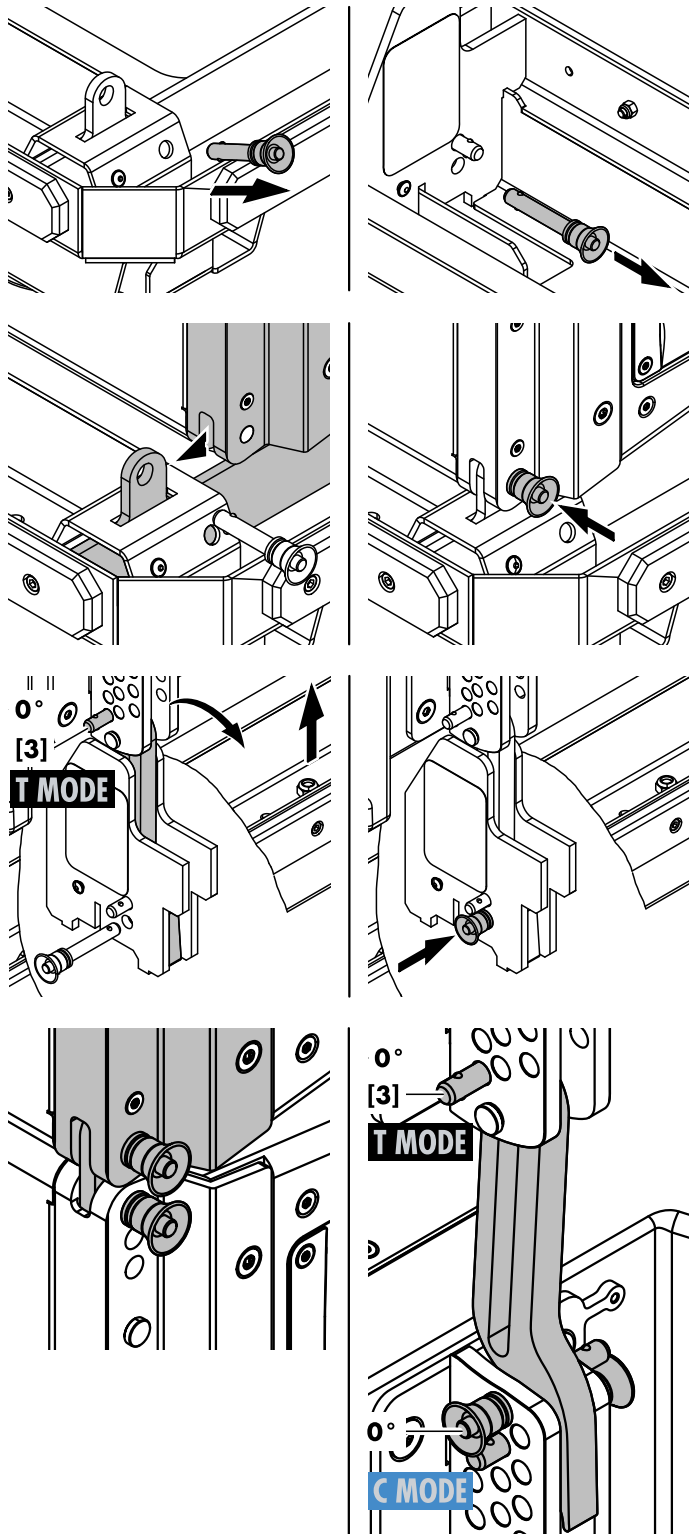

Loading the cart

Prepare the Front and Splay links of the first cabinet as described in ⇒ Chapter 3.16 "Cabinet rigging mechanism" on page 23.

1. At the front of the cart, release the Locking pins from their park positions on both sides.
2. At the rear center Splay link slot, release the bottom Locking pin.
3. Attach the first cabinet to the front supports of the cart and reinsert the Locking pins on both sides.
4. At the rear of the cabinet, ensure Locking pin **[3]** is inserted into the 0° hole of the inner hole grid (⇒ Red labeled hole **○ - T MODE**).
5. Insert the Splay link into the Splay link slot.
6. Lift the back of the cabinet until the Splay link has engaged and reinsert the bottom Locking pin to fix the link in place.
7. Finally, extend the Front links of the first cabinet to attach the next cabinet.
8. For the remaining three cabinets, proceed in the same manner.
9. Attach the next cabinet to the previously extended Front links of the first cabinet and reinsert its Locking pins on both sides.
10. At the rear of the cabinet, ensure Locking pin **[3]** of the upper cabinet is inserted into the 0° hole of the inner hole grid (⇒ Red labeled hole **○ - T MODE**) and the Splay link is fixed to the 0° hole of the center hole grid of the bottom cabinet (⇒ Red labeled hole **○ - C MODE**).

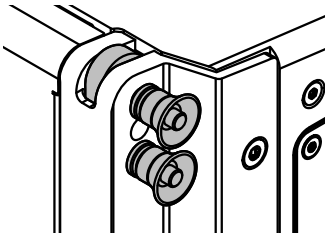

11. On the last cabinet, ensure the Front links are stored in their park positions.

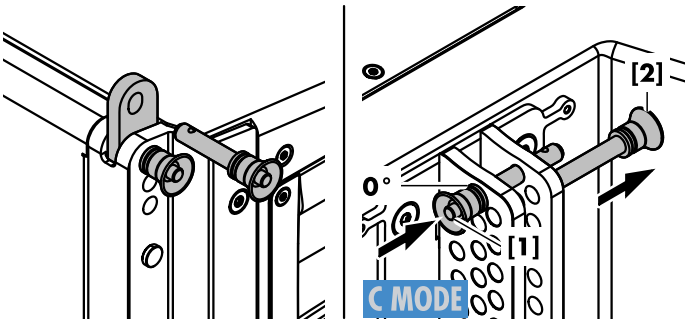

Attaching the flying frame

The touring cart is also intended to carry the flying frame during transport. To attach the flying frame, proceed as follows:

1. Extend the Front links of the cabinet on both sides.
2. At the rear, release Locking pin **[2]** and ensure Locking pin **[1]** is inserted into the red marked **0°** hole (⇒ Red labeled holes **○ - C MODE**) at the top of the center hole grid.

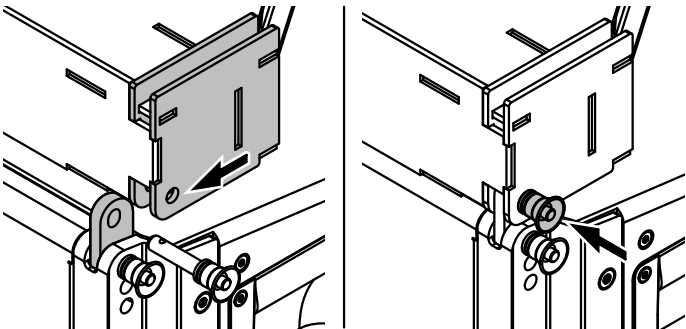

3. Attach the flying frame to the Front links of the cabinet and reinsert the Locking pins on both sides.

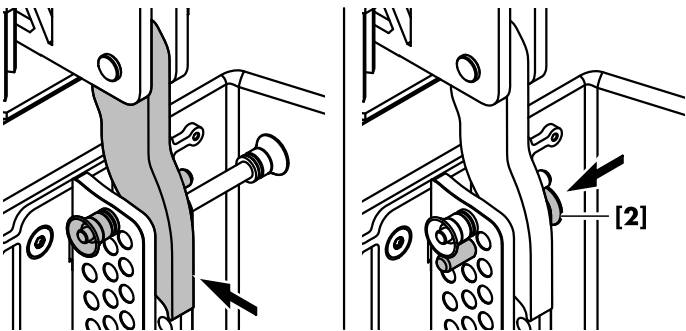

4. At the rear, insert the flying frame's Rear link into the rear rigging strand of the cabinet.
5. Raise the back of the flying frame until the Rear link has engaged.
6. Reinsert the Locking pin **[2]** (Safety pin).

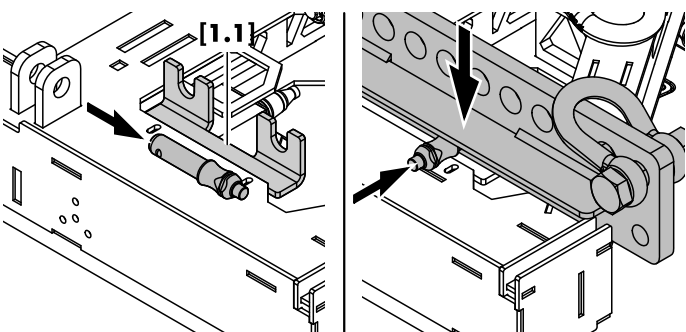

Storing the load beam

The XSL Load beam is stored and fixed on top of the XSL Flying frame.

For this purpose, the flying frame provides a dedicated slot **[1.1]** to fix the load beam in place.

To fix the load beam, use the Locking pin of the front fixing slot of the flying frame, as shown in the graphic opposite.

3.17.2 E7812 Touring cart XSL-SUB

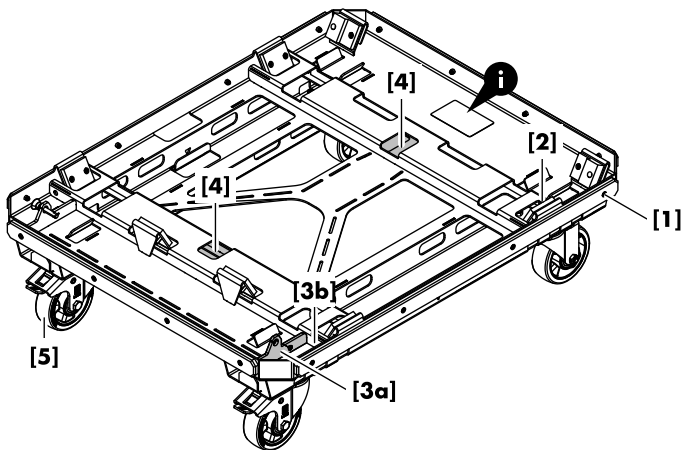

Pos.	Component	Description
[1]	E7812	Touring cart 2 x XSL-SUB Total weight: 190 kg (420 lb), incl. XSL-SUB Mounting frame and XSL-SUB Adapter frame. Dimensions: H x W x D (cm) 156 x 80 x 100 H x W x D (inch) 62 x 31.5 x 39.5
[2]		Eight guide lugs at the front, left/right and rear of the cart.
[3a] [3b]		Dedicated supports [3a] at the front left and right and corresponding Locking pins [3b] to fix the Z5783 XSL-SUB Adapter frame when stored in the cart.
[4]		Two slots acting as guide rail allowing the Z5783 XSL-SUB Adapter frame to be stored in the cart.
[5]		Four heavy duty wheels (two of them are brake wheels) 125 x 40 mm.
(i)		Touring cart instruction label providing vital safety and rigging instructions.

Loading the cart

When the cart is loaded with XSL-SUB cabinets only, simply stack the cabinets onto the cart and interconnect them using their Front and Rear links as follows:

1. Attach the first cabinet onto the cart with the front grill facing towards the instruction label (i).
↳ Due to the guide lugs [2] at the front, left/right and rear of the cart, the cabinet is centered on the cart.
2. Attach the second cabinet and interconnect the cabinets with their Front and Rear links.

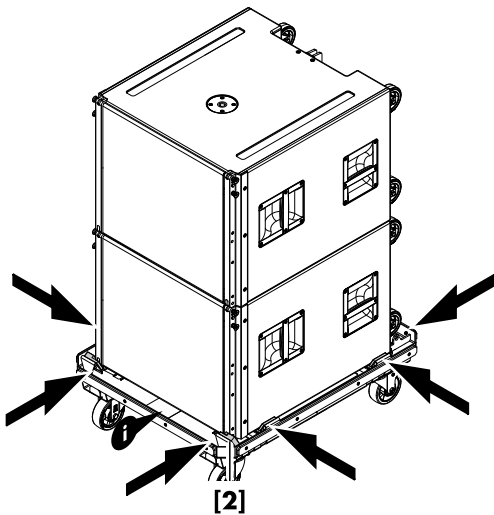

XSL-SUB Adapter frame storage tray

The cart also allows the storage of a SUB cabinet assembly with the XSL-SUB Adapter frame already mounted to the bottom SUB cabinet.

For this purpose, the cart is equipped with dedicated supports on the front left and right **[3a]** and corresponding Locking pins **[3b]** as well as two slots **[4]** acting as guide rail to fix the assembly in place.

To store the assembly in the cart, proceed as follow:

1. Slowly lower the assembly onto the cart until the front supports fit into the slots of the adapter frame.
2. Release the Locking pins on the cart from their park positions.
3. Insert the Locking pins to the frame on both sides and ensure they are fully inserted and locked.

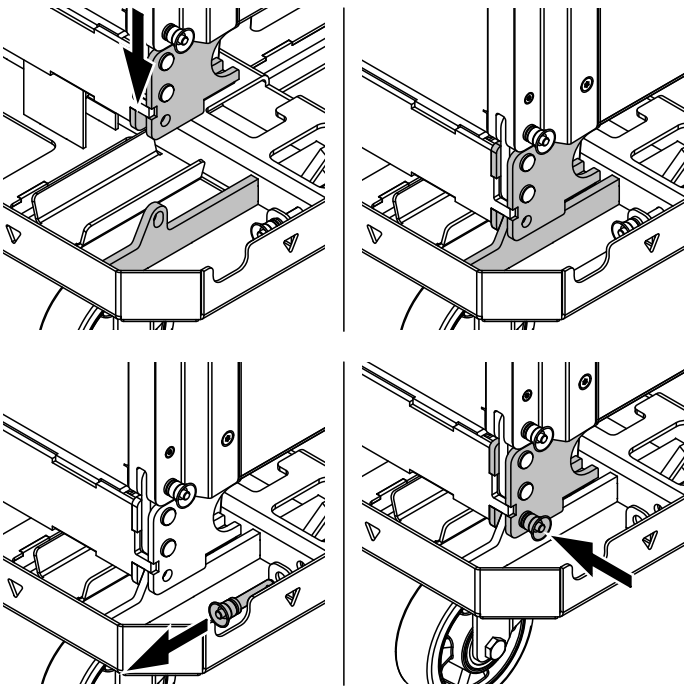

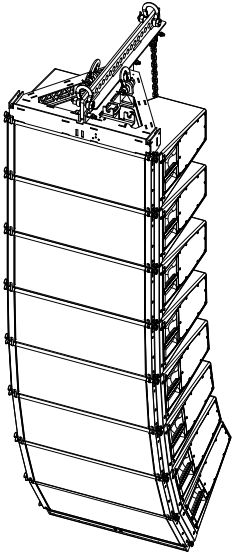

XSL8/XSL12 Line array 8-deep, Compression mode setup

Refer to:
 ⇒ Chapter 6 "Compression mode setup" on page 34.

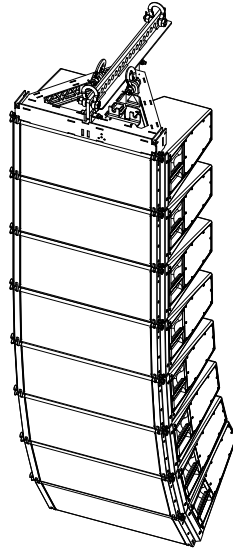

XSL8/XSL12 Line array 8-deep, Tension mode setup

Refer to:
 ⇒ Chapter 7 "Tension mode setup" on page 40.

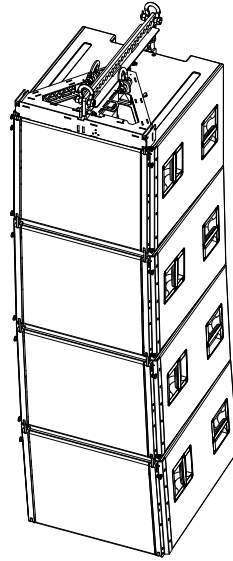

XSL-SUB column with 2.5° splay between the cabinets

Refer to:
 ⇒ Chapter 9 "SUB columns" on page 45.

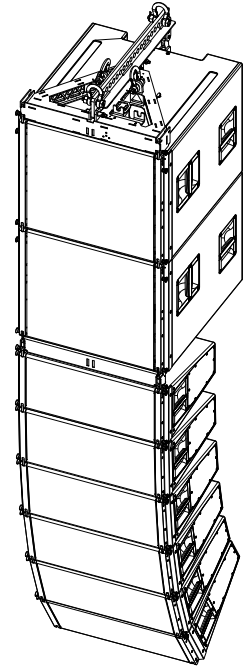

Mixed array setup

Refer to:
 ⇒ Chapter 10 "Mixed array setup" on page 49.

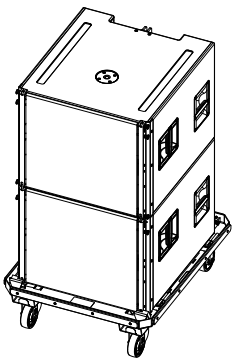

XSL-SUB/XSL-GSUB ground stack setup

Refer to:
 ⇒ Chapter 11.1 "XSL-SUB/XSL-GSUB ground stack" on page 52.

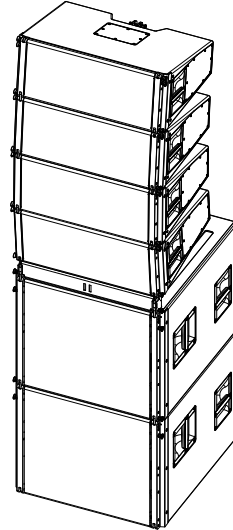
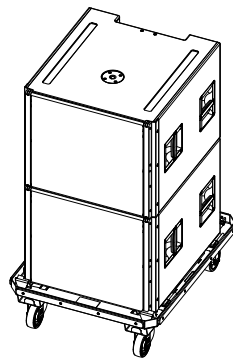

Mixed ground stack setup

Refer to:
 ⇒ Chapter 11.2 "Mixed ground stack setup" on page 52.

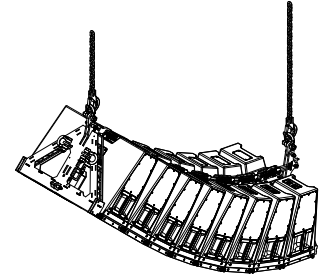

XSL Pullback mode setup

Refer to:
 ⇒ Chapter 8 "XSL Pullback mode setup" on page 44.

5.1 Setup preparation

Notes

For both, Compression and Tension mode setups, it is assumed that the Touring carts are appropriately loaded and the flying frame is already attached as described in ⇒ Chapter 3.17 "XSL Touring carts" on page 25.

Preparatory steps

Check the acoustical and mechanical setup using ArrayCalc and prepare enough printouts for each array. Alternatively, the ArrayCalc Viewer App can be used for this purpose.

The plan enables the riggers to set up the suspension points, the securing points and the chain hoists.

When on site first:

- Clear the working areas and ensure there is enough space to set up and lift the array.
- Check that the hoists are exactly in the specified position.
- Ensure the chains are not twisted.

Inspections before setup

Before setting up the array, carry out a visual inspection of all system components for faults. This also includes the loudspeakers and in particular the rigging parts of the cabinets (Front and Splay/Rear links).

Damaged components must be withdrawn from use immediately.

Please follow the instructions given in ⇒ Chapter 15 "Care and maintenance" on page 63.

5.1.1 Attaching the Load beam to the Flying frame



WARNING!

Potential risk of personal injury and/or damage to material!

The two Locking pins of the flying frame's load beam slots at the center front and rear of the frame carry the load of the entire array.

For this reason, ensure the corresponding Locking pins are fully inserted and locked.

The attachment of the load beam applies to both, Compression and Tension mode setups.

Depending on the desired operating mode (STANDARD MODE or FRONT EXTENSION), attach the load beam as follows:

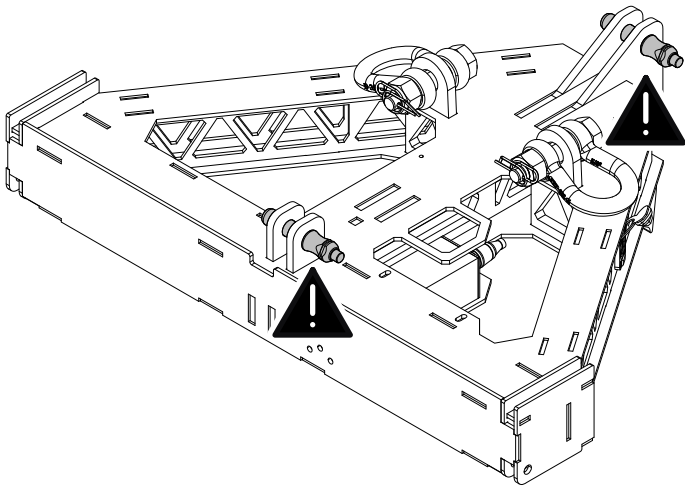

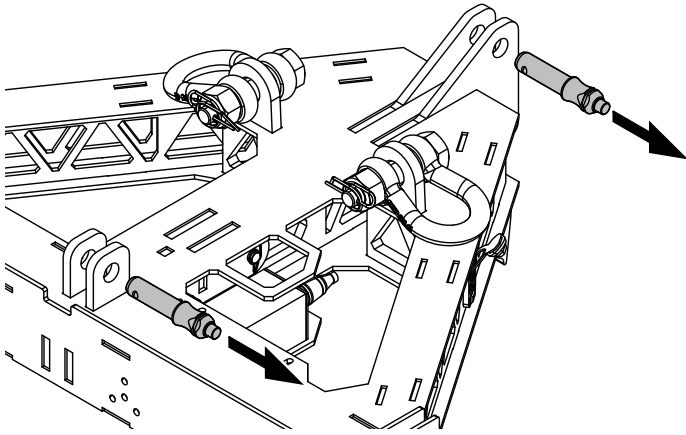

1. On the flying frame, release the Locking pins of the load beam slots at the center front and rear of the frame.

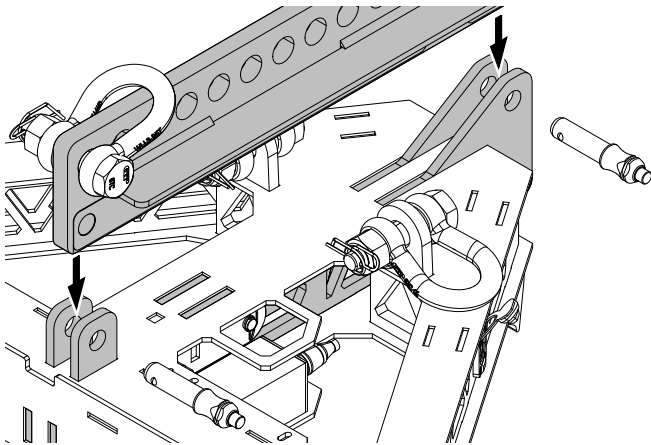

2. Attach the load beam to the slots on the frame according to the desired operating mode.

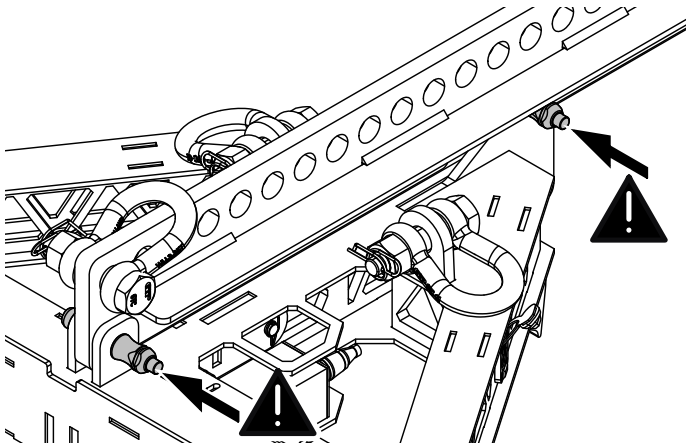

3. Reinsert and lock the two Locking pins.
↳ Ensure the Locking pins are fully inserted and properly locked.

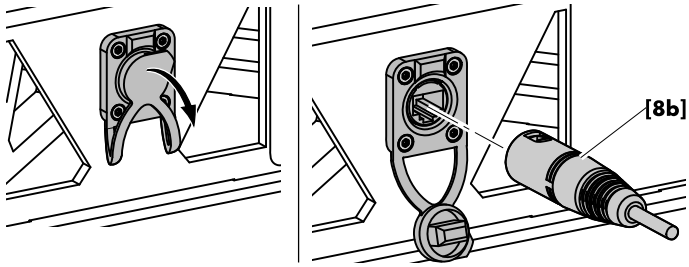

5.1.2 Connecting the d&b ArraySight sender unit



WARNING!

Potential risk of personal injury.

Please observe the safety instructions provided in the ArraySight manual.

⇒ Connect the ArraySight sender unit using the enclosed d&b K6006.200.00 CAT5e 1:1 cable **[8b]** and perform a basic test of the laser unit.

For this purpose, the SL-Series flying frames are equipped with a dedicated etherCON connector socket which is directly accessible on the frame to allow for easy connection, as shown in the graphic opposite.

↳ For detailed information on the d&b ArraySight laser inclinometer system, please refer to the ArraySight manual which is also provided with the SL-Series flying frames.

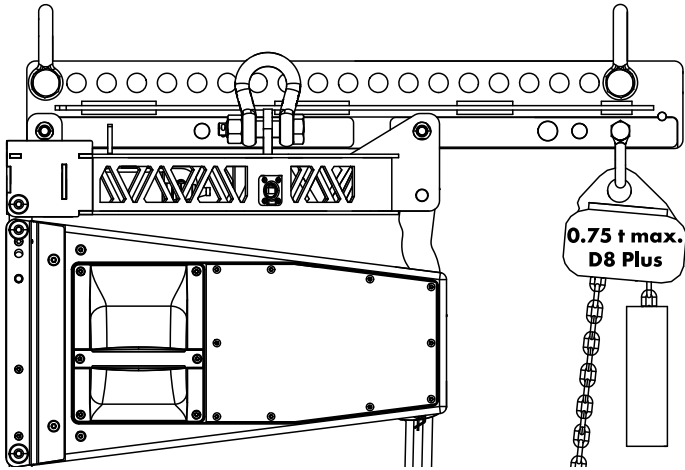

For Compression mode setup, we recommend the use of the dedicated d&b XSL compression set including the B2467.072 Crank lever hoist to manually curve the array.

! WARNING!
Potential risk of personal injury and/or damage to material.

When using a motor hoist instead of the lever hoist, observe the following:

- The maximum permitted compression force is **750 kg (0.75 t/7.5 kN)**.
 The hoist overload clutch must be correspondingly adjusted.
- The motor hoist must be equipped with two independent brakes (according to the German **D8 Plus** standard).
- Observe your local legal requirements and Rules for the Prevention of Accidents (RPA).

Comp.	
N/A	Depending on the total length (total number of cabinets) of the array, the motor hoist may not be able to apply the required force to completely curve (compress) the entire array in Compression mode setup.
-	In this case, ArrayCalc indicates those cabinets from top to bottom (marked as "--") that need to be curved manually in Tension mode first, cabinet by cabinet.
-	
OK	The remaining cabinets, marked as "OK" (OK), can then be curved (compressed) by the motor hoist.
OK	
OK	

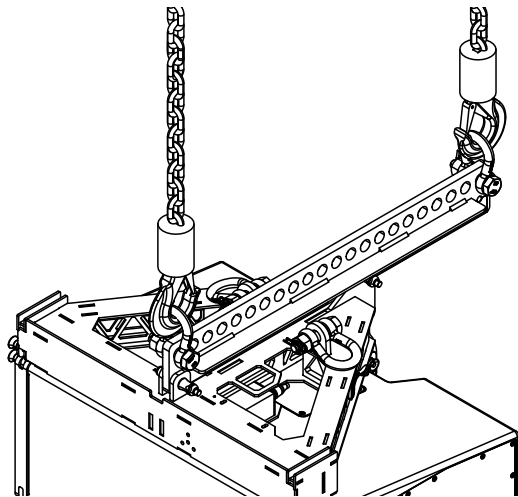

Provided...:

- The touring cart is loaded as described in ⇒ Chapter 3.17.1 "E7809 Touring cart XSL8/XSL12" on page 25 and in position.
- The load beam has already been attached to the flying frame, as described in the previous section ⇒ Chapter 5.1.1 "Attaching the Load beam to the Flying frame" on page 31 and the hoists are connected.
- The safety chain has already been attached to the flying frame, as described in ⇒ Chapter 3.15 "Secondary safety" on page 23.

... proceed as follows:

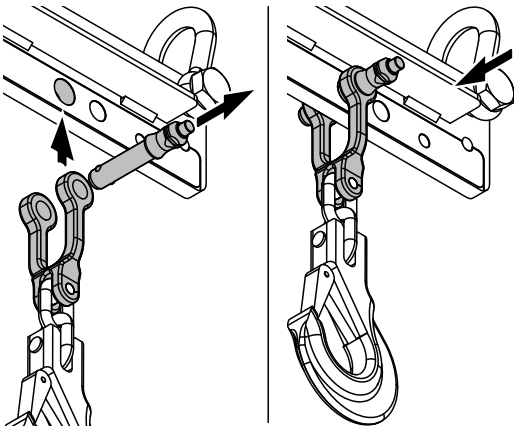

1. Attaching the cable pick (Z5713)

1. Release the Locking pin of the coupling shackle.
2. Attach the coupling shackle to the dedicated hole position at the rear end of the load beam.
3. Reinsert the Locking pin and ensure the pin is fully inserted and locked.
4. Set suitable lengths of the individual loudspeaker cables, and attach split sets when applicable and connect the cables subsequently during the entire setup procedure.

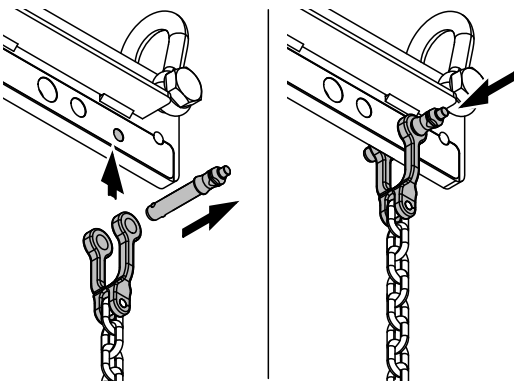

2. Attaching the compression chain

1. Release the Locking pin of the coupling shackle.
2. Attach the coupling shackle to the dedicated hole position at the rear end of the load beam.
3. Reinsert the Locking pin and ensure the pin is fully inserted and locked.

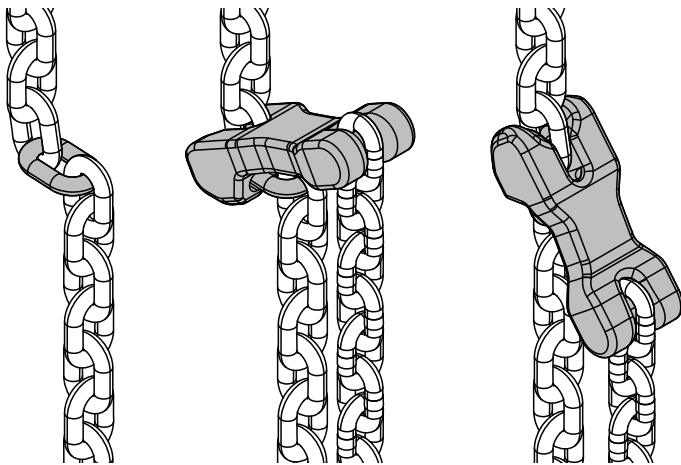

3. Attaching the crank lever hoist

At a certain point during setup, the grab link (shortening link) of the lever hoist has to be attached to the compression chain. Its position depends on the length and the final curvature of the array and is calculated and indicated in ArrayCalc («Sources» view ⇒ «Grab link position»).

1. Attach the grab link, as shown in the graphic opposite.
2. Ensure the grab link is properly attached.

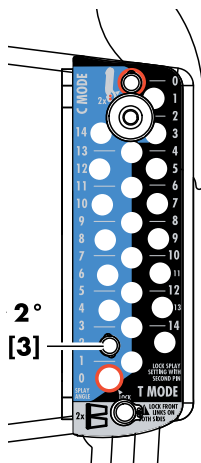

4. Preset the splay angles

On the inner and center hole indices, preset the splay angles (e.g. 2°) according to your ArrayCalc project using Locking pin [3] (See also ⇒ Chapter 2 "XSL rigging modes - 2 in 1" on page 6).

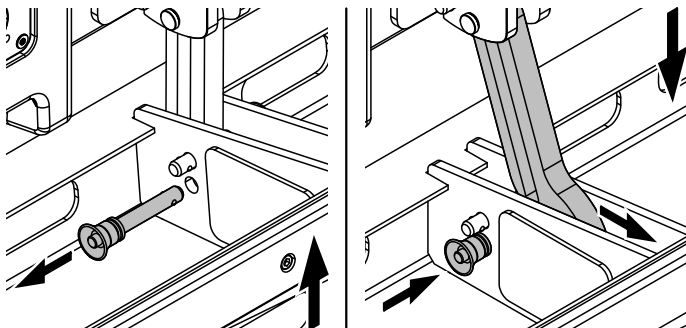

5. Dismantling the touring cart

1. Lift the entire assembly to a height of approx. 30 cm (1 ft) above ground.
2. At the center rear Splay link slot, release the bottom Locking pin.
3. Slightly lift the cart and disengage the Splay link.
4. Reinsert the Locking pin and lower the cart.

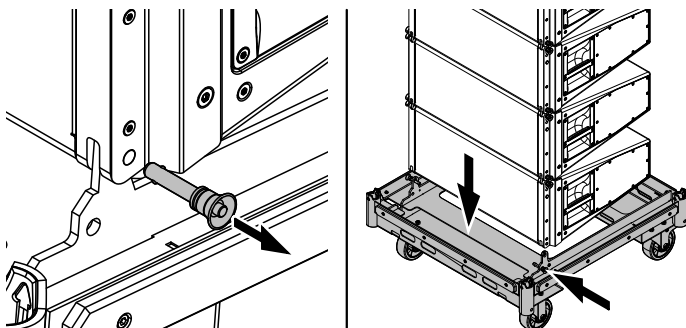

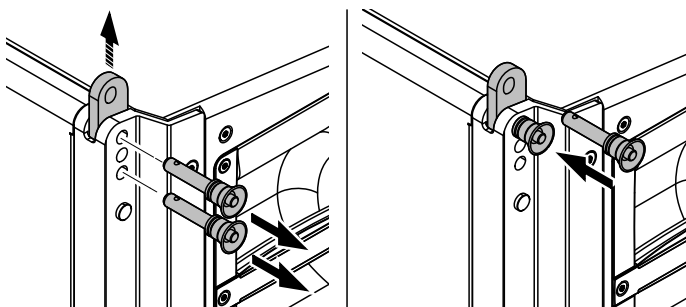

5. With one person on each side, release the Locking pins at the front of the cart.
6. Lower the cart, reinsert the Locking pins into their park positions and put the cart aside.

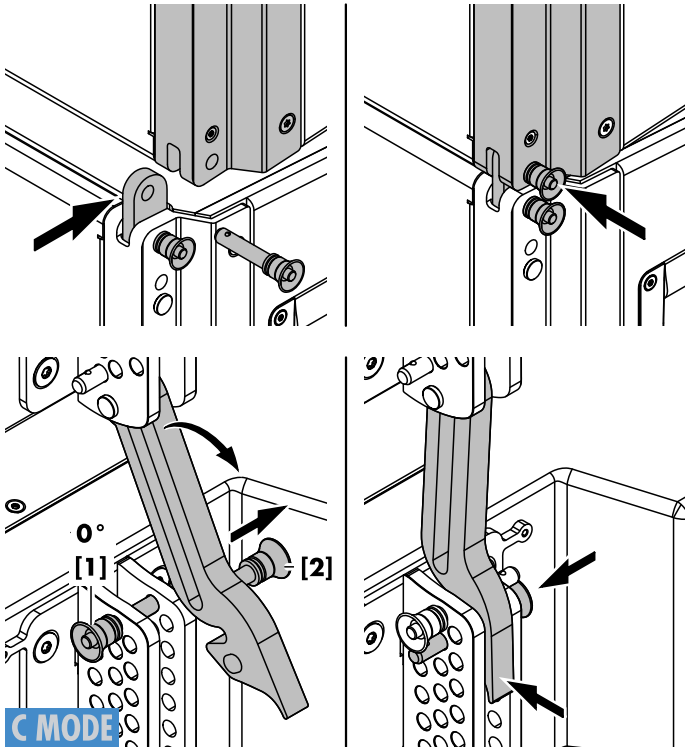

6. Attaching the next assembly

1. Lift the first assembly to allow the next assembly to be positioned below.
2. Position the next assembly and extend the Front links of the uppermost cabinet.



3. Lower the array until the Front links of the top cabinet in the cart fit into the slots at the front of the bottom cabinet of the array.
4. Insert and lock the second Locking pins of the cabinet's Front links on both sides.
5. On the rear rigging strand, release Locking pin [2] and check Locking pin [1] is set to 0° (⇒ Red labeled holes  - C MODE).
6. Pull the Splay link of the upper cabinet out of its temporary park position.
7. Slightly lower the array and fold the Splay link into the rigging strand.
8. Slightly lift the array until the Splay link has engaged into the preset Locking pin [1].
9. Insert and lock Locking pin [2] (Safety pin) to secure the Splay link in place.
10. Lift the entire array approx. 30 cm (1 ft) above ground and dismantle the Touring cart as described previously.
11. Preset the splay angles as described previously.

For the attachment of further touring cart assemblies, proceed in the same manner.

7. Attaching the compression frame

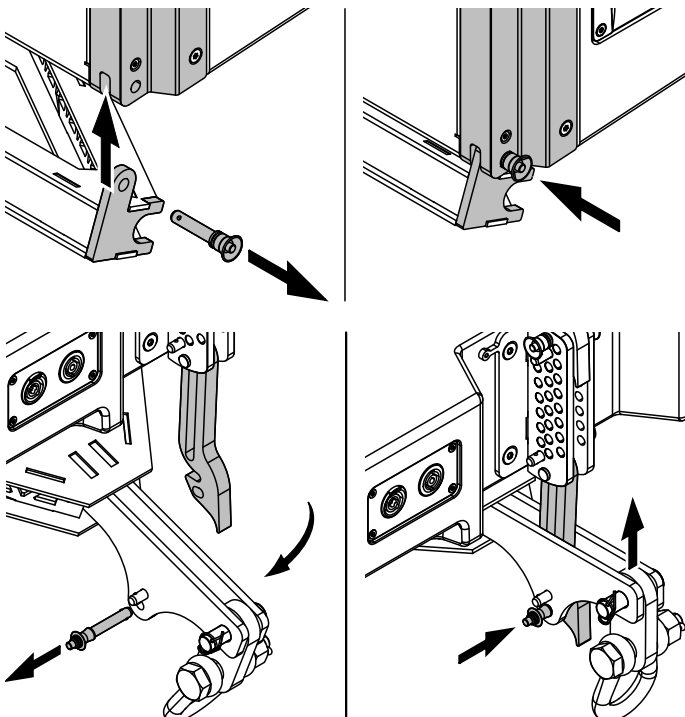

1. Lift the entire array to a suitable working height.
2. With one person on each side, release the Locking pins at the front of the compression frame.
3. Insert the front studs into the corresponding slots at the front of the cabinet.
4. Reinsert the Locking pins on both sides.
5. At the center rear, release the bottom Locking pin of the compression frame's Splay link slot.
6. Pull the Splay link out of its temporary park position.
7. Raise the frame until the Splay link has engaged into the Locking pin.
8. Reinsert the bottom Locking pin (Safety pin) to secure the Splay link in place.

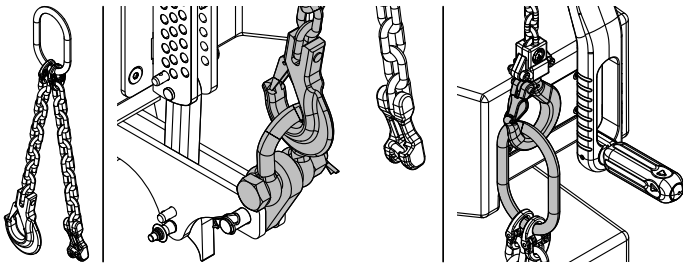

8. Attaching the compression frame master link

1. Attach the hook to the shackle of the compression frame.
2. Attach the O-ring of the master link to the hook on the housing of the lever hoist.

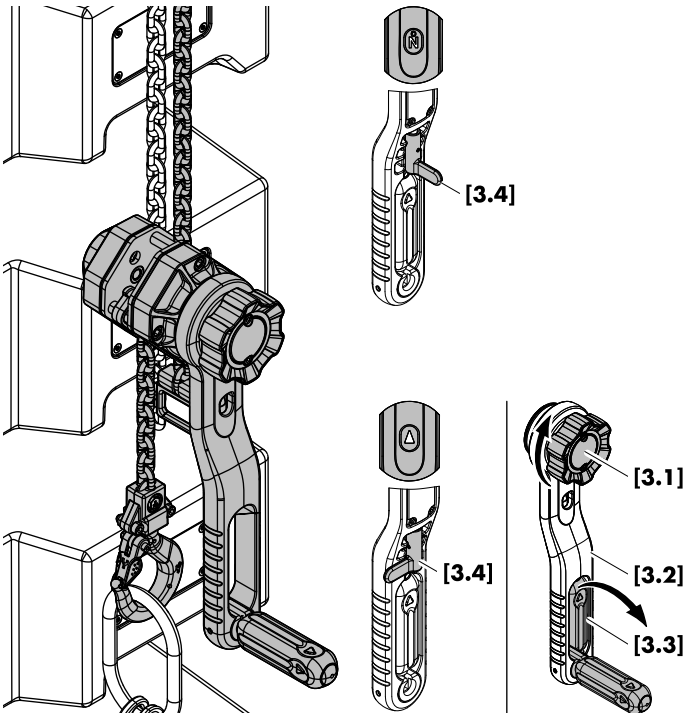

9. Adjusting the lever hoist

To adjust the lever hoist, proceed as follows:

- ⇒ Set the lever mode selector **[3.4]** to the neutral position (⇒ **N**).
- ↳ In this mode, the load chain can be freely pulled through the hoist to its required length.

10. Curving the array

Before curving the array, recheck the actual status of the entire assembly according to the checklist given in ⇒ Chapter 12 "Safety and system checks" on page 57.

To curve the array, proceed as follows:

1. Set the lever mode selector **[3.4]** to the lifting position (⇒ **Δ**).
2. Turn the free chain knob **[3.1]** clockwise until the hoist has engaged to its load chain.
3. Fold out the crank **[3.3]**.
4. Operate the lever **[3.2]** clockwise until the array is completely curved.
 - ↳ The maximum permitted compression force has been achieved when the lever kinks.
5. Stop further operation and set the lever mode selector **[3.4]** back to the neutral position (⇒ **N**) and fold the crank **[3.3]** back into place.

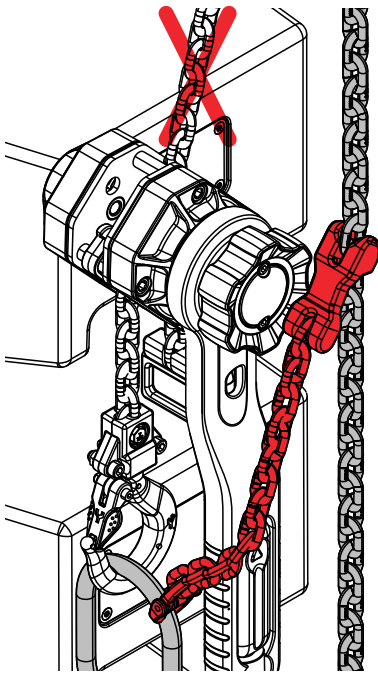

11. Securing the lever hoist



WARNING!

Potential risk of personal injury and/or damage to material.

The second chain leg of the Compression frame master link is intended as a secondary safety device to secure (bridge) the Crank lever hoist in the event that its primary suspension or its breaking system should fail.

- Therefore the grab link of the chain leg has to be attached to the **compression chain** and **NOT** to the load chain of the hoist.
- Ensure the grab link is properly attached as shown in the graphic below.

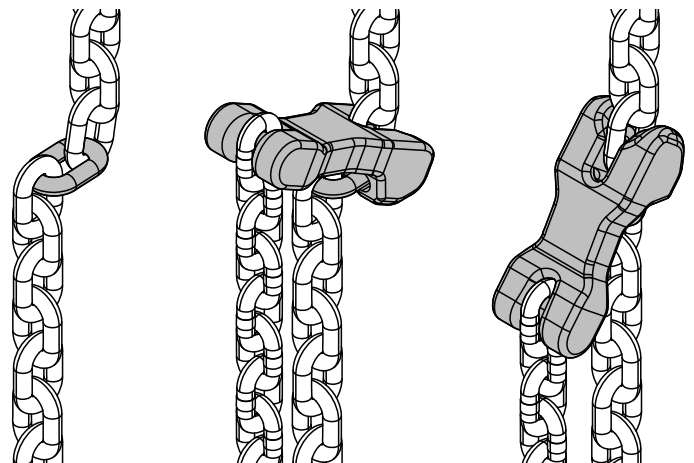

12. Check the assembly

Before hoisting the array to its operating position, recheck the actual status of the entire assembly according to the checklist given in ⇒ Chapter 12 "Safety and system checks" on page 57.

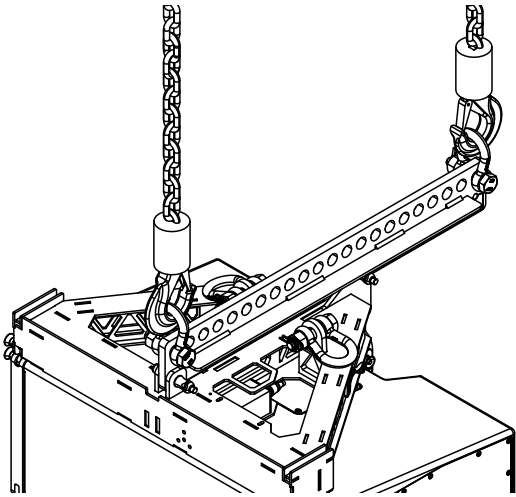

Provided...

- The touring cart is loaded as described in and in position.
- The load beam has already been attached to the flying frame, as described in the previous section ⇒ Chapter 5.1.1 "Attaching the Load beam to the Flying frame" on page 31 and the hoists are connected.
- The safety chain has already been attached to the flying frame, as described in ⇒ Chapter 3.15 "Secondary safety" on page 23.

... proceed as follows:

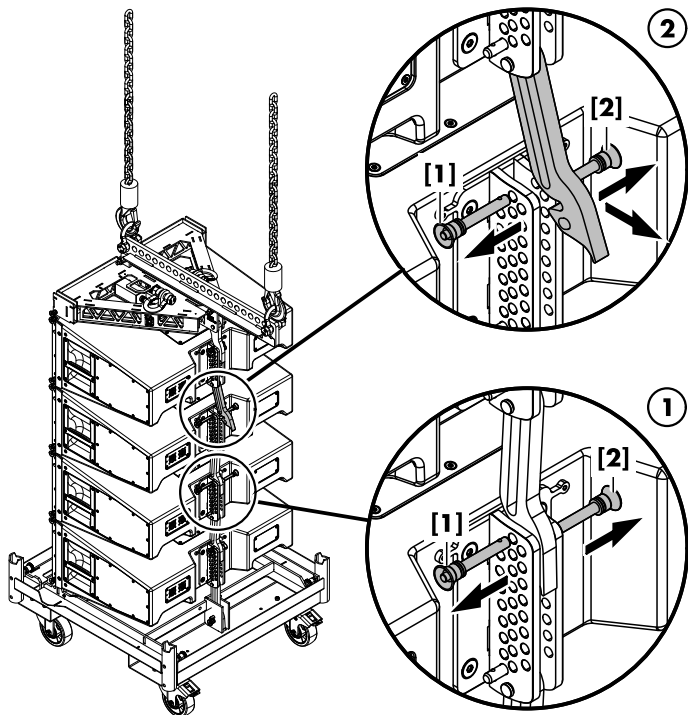

1. Setting the splay angles

The Splay links have to be engaged manually cabinet by cabinet. Proceed as follows:

1. On the cabinet, on which the splay is to be set, first release the two Locking pins (pin **[1]** and **[2]**) on the cabinet below.
 - ↳ This will release the Splay link and the cabinet becomes movable.
2. On the cabinet itself also release the two Locking pins (pin **[1]** and **[2]**) and fold out the Splay link of the upper cabinet.

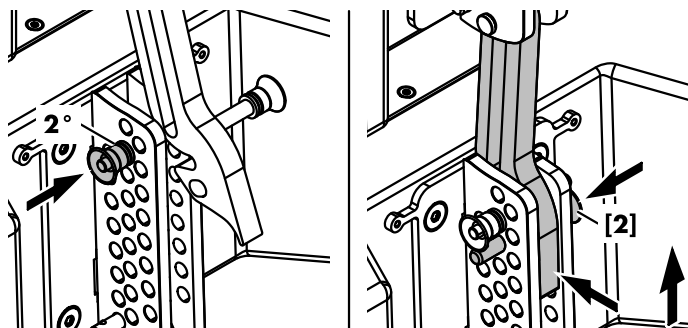

3. Preset the splay angle (e.g 2°).
4. Insert the Splay link of the upper cabinet into the rigging strand.
5. Slightly lift the back of the cabinet until the Splay link has engaged and reinsert Locking pin **[2]** (Safety pin).

6. For the next two cabinets proceed in the same manner.

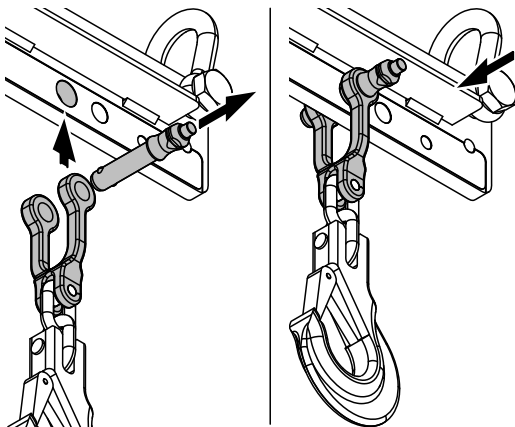
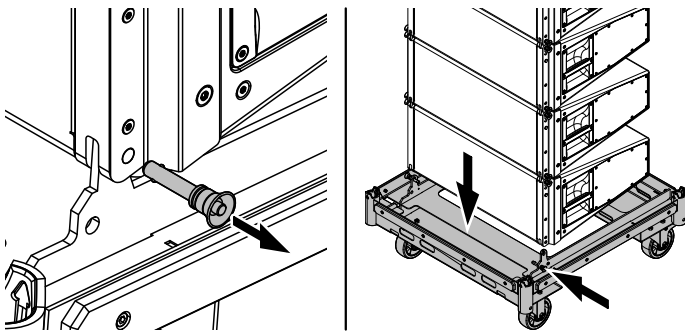
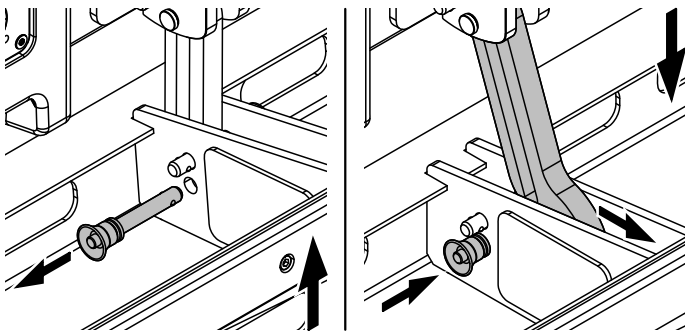

2. Dismantling the touring cart

1. Lift the entire assembly to a height of approx. 30 cm (1 ft) above ground.
2. At the center rear Splay link slot, release the bottom Locking pin.
3. Slightly lift the cart and disengage the Splay link.
4. Reinsert the Locking pin and lower the cart.
5. With one person on each side, release the Locking pins at the front of the cart.
6. Lower the cart, reinsert the Locking pins into their park positions and put the cart aside.

3. Attaching the cable pick (Z5713)

1. Release the Locking pin of the coupling shackle.
2. Attach the coupling shackle to the dedicated hole position at the rear end of the load beam.
3. Reinsert the Locking pin and ensure the pin is fully inserted and locked.
4. Set suitable lengths of the individual loudspeaker cables, and attach split sets when applicable and connect the cables subsequently during the entire setup procedure.

4. Attaching the next assembly

Due to the weight of the cabinets, further assemblies cannot be attached out of the cart in one go. The Splay links have to be engaged manually cabinet by cabinet. Proceed as follows:

1. Lift the first assembly to allow the next assembly to be positioned below.
2. Position the next assembly and extend the Front links of the uppermost cabinet.
3. Lower the array until the Front links of the top cabinet in the cart fit into the slots at the front of the bottom cabinet of the array.
4. Insert and lock the second Locking pins of the cabinet's Front links on both sides.
5. At the rear, insert Locking pin **[1]** into the desired splay angle hole (e.g. 8°).
6. On the cabinet below, release the Splay link (Locking pin **[1]** and **[2]**).
7. Lift the back of the first cabinet of the assembly until the Splay link has engaged.
8. Reinsert Locking pin **[2]** (Safety pin).
9. For the remaining cabinets, proceed in the same manner.

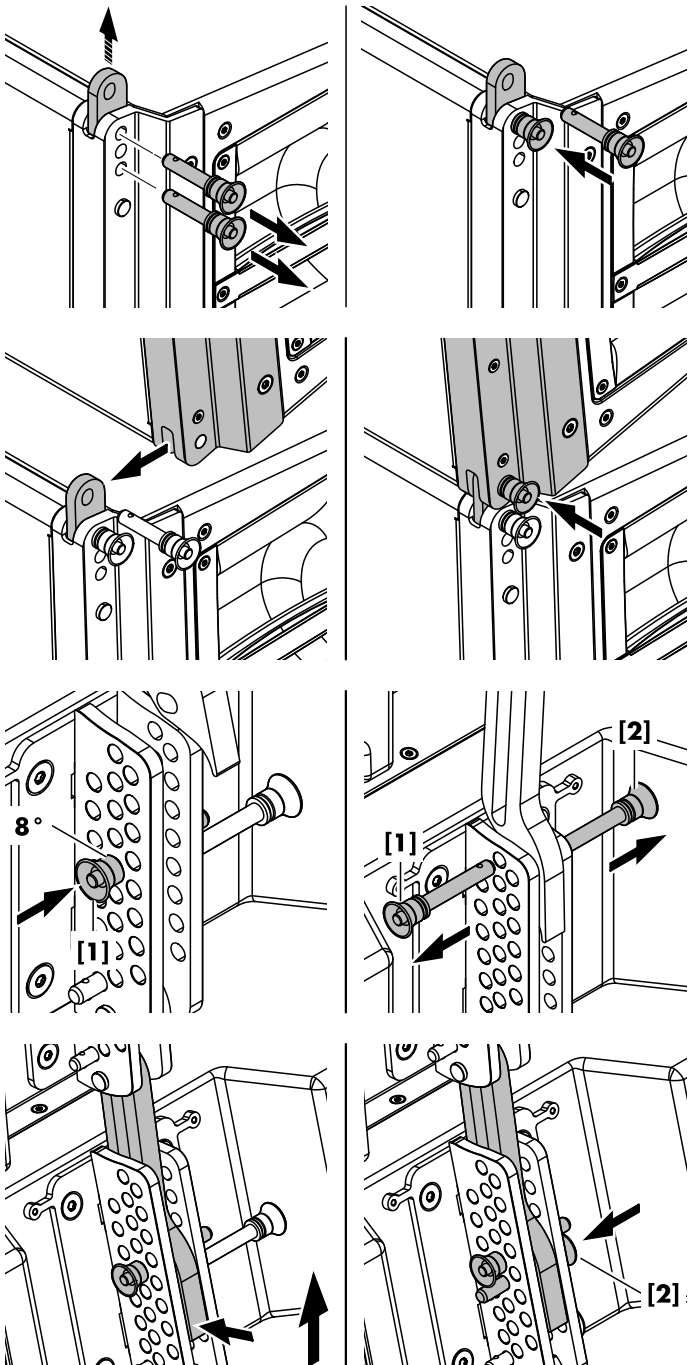

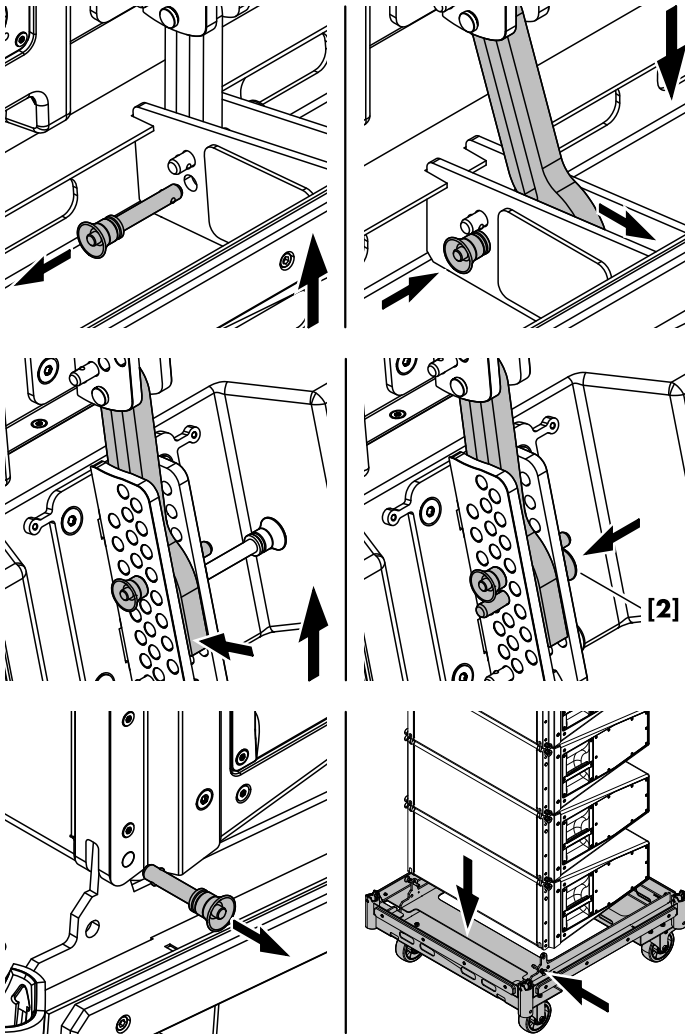

10. For the last cabinet, release the bottom Locking pin at the center rear Splay link slot of the cart.
11. Slightly lift the cart and disengage the Splay link.
12. Reinsert the Locking pin and lower the cart.

13. Lift the back of the cabinet until the Splay link has engaged.
14. Reinsert Locking pin **[2]** (Safety pin).

15. Finally, lift the entire assembly to a height of approx. 30 cm (1 ft) above ground.
16. With one person on each side, release the Locking pins at the front of the cart.
17. Lower the cart, reinsert the Locking pins into their park positions and put the cart aside.

For the attachment of further touring cart assemblies, proceed in the same manner.

5. Check the assembly

Before hoisting the array to its operating position, recheck the actual status of the entire assembly according to the checklist given in ⇒ Chapter 12 "Safety and system checks" on page 57.

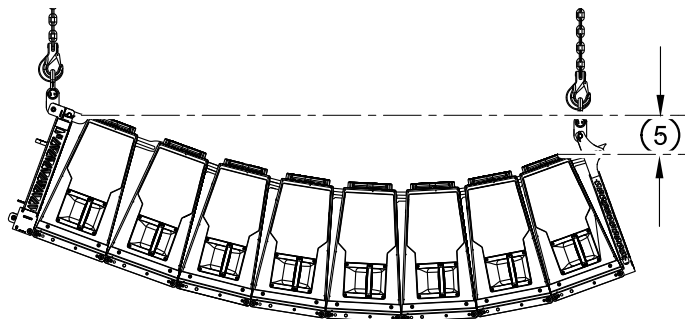
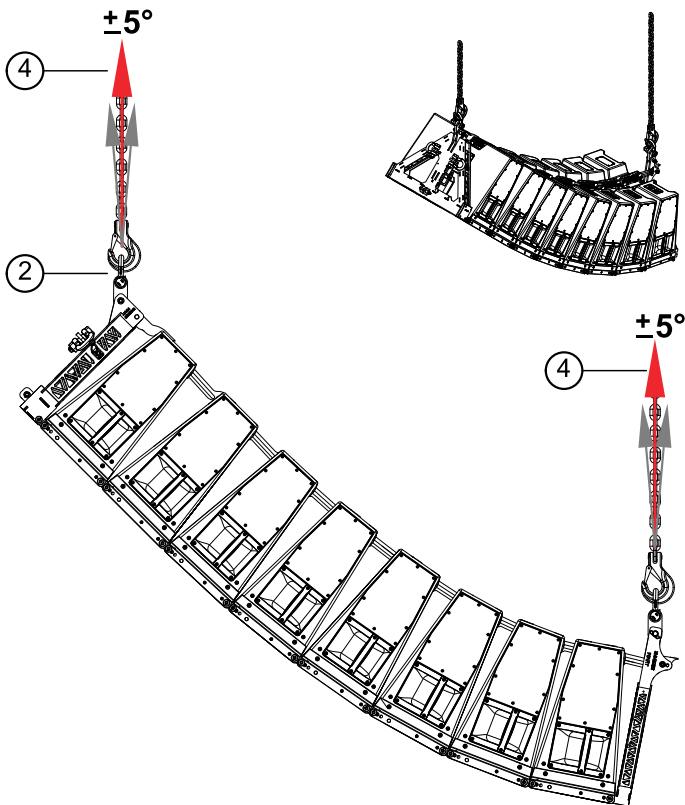
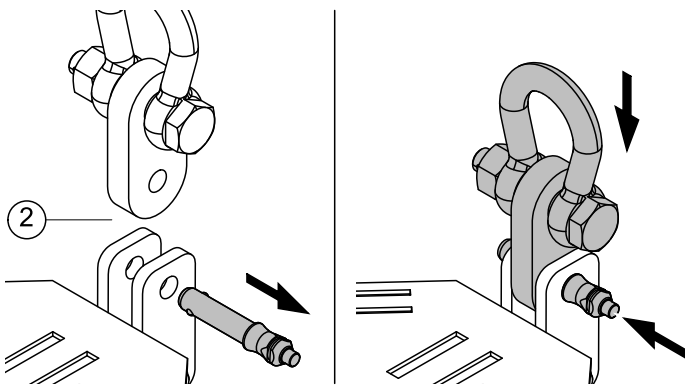

Specifications and recommendations

NOTICE!

Load safety information

XSL-TOP cabinets can be deployed with any splay angle combination and any total vertical inclination of the entire array using an additional pullback point at the bottom of the array, as long as the conditions described below are met. For this purpose, the d&b Z5792 XSL Pullback frame is used. The assembly of the frame is similar to the assembly of the d&b Z5774 XSL Compression frame. For assembly instructions, please refer to the Compression mode setup section and follow step ⇒ "7. Attaching the compression frame" on page 37.

1. Tension mode rigging

The array **must** be set up in Tension mode.

For assembly instructions, please refer to ⇒ Chapter 7 "Tension mode setup" on page 40.

- It is necessary to suspend the array directly from the rear pick point of the flying frame using the suspension device that is enclosed with the XSL Pullback frame.

↳ This ensures a maximum angle range between array and hoist chain without any hooks or shackles touching the frame, something which could cause unsafe load conditions for these components.

When using an O-Ring for this purpose, make sure the O-Ring is big enough to move freely without mechanical obstruction.

- In ArrayCalc, select the «**flown pullback**» mounting method.

↳ ArrayCalc will calculate the load conditions and force direction of each individual connection. Based on these results, the actual resulting angles will be chosen depending on the force direction of each interconnection.

- The hoist connector and pullback chain must always lift the array straight upwards (⇒ max. diagonal pull: $\pm 5^\circ$).

- The height of the first cabinet must always be greater than the height of the last cabinet.

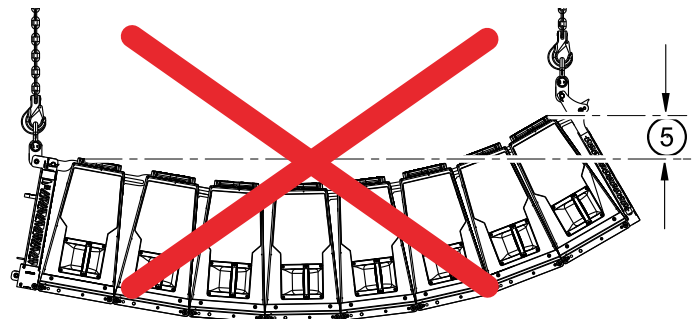

9.1 Limitations

NOTICE!

A maximum of 15 x XSL-SUB cabinets are allowed to be suspended, including all rigging components.

9.2 Rear link of the flying frame

Rear link position

By factory default, the Rear link is attached to the flying frame for the deployment of XSL-TOP cabinets.

To attach XSL-SUB cabinets, the Rear link position has to be changed and moved to the dedicated hole position on the load beam. For this purpose, a corresponding adapter (extender) is provided with the flying frame.

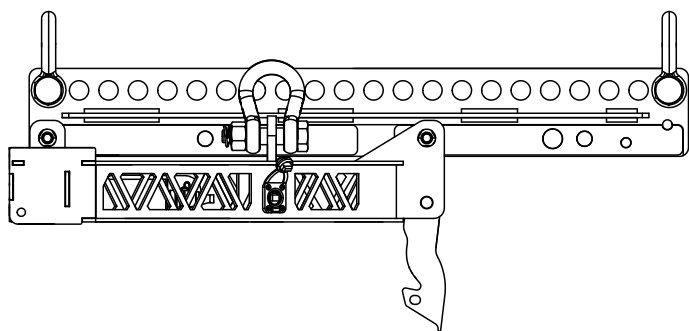

Rear link of the frame in default position

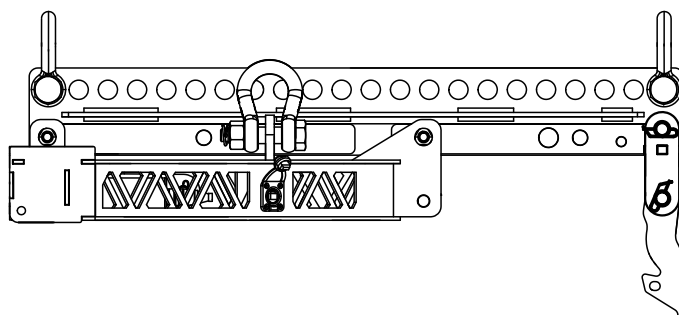

Rear link of the frame in SUB position

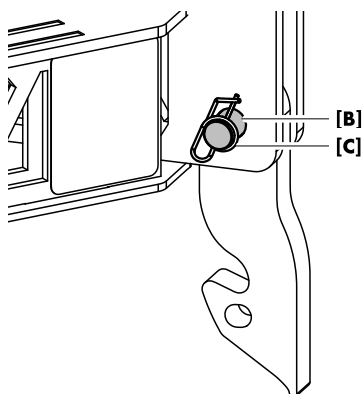

Changing the Rear link position

WARNING!
Potential risk of personal injury and/or damage to material!

The fixing bolt **[B]** of the frame's Rear link bears the full load of the array.

It is essential that the bolt is fitted correctly and secured by a locked ring cotter **[C]**.

To change the Rear link position, proceed as follows:

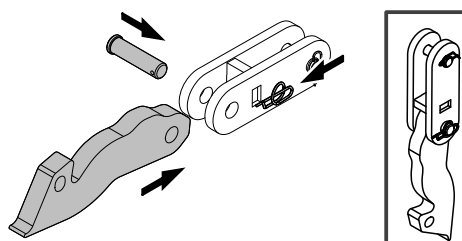
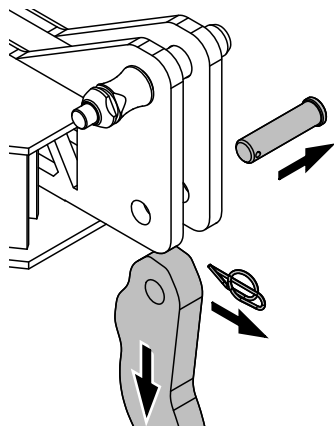
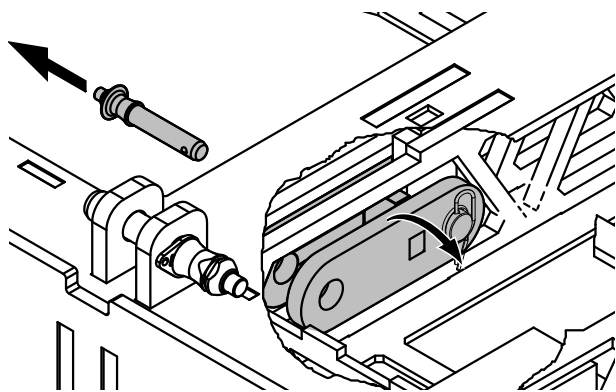

XSL-SUB:
INSERT
ADAPTER
AND ADD
REAR LINK

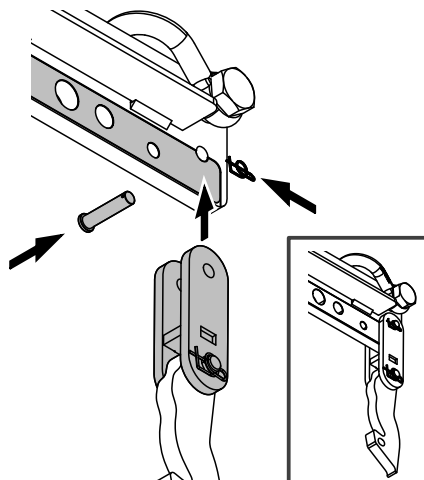

Rear link adapter

The Rear link adapter is located in its park position at the front of the Frame's center truss.

1. Unlock and remove the Locking pin holding the Rear link adapter in its park position.
2. Take off the Rear link adapter.
3. For the Rear link of the frame, unlock the ring cotter of its fixing bolt.
4. Remove the fixing bolt and take off the link.
5. Attach the Rear link to the adapter.
6. Insert the fixing bolt.
7. Secure the fixing bolt using the ring cotter and ensure the ring cotter is properly fitted and locked.
8. Attach the Rear link assembly to the dedicated hole position of the load beam.
9. Insert the fixing bolt.
10. Secure the fixing bolt using the ring cotter and ensure the ring cotter is properly locked.

9.3 SUB column setup

Provided the touring cart is loaded with the SUB cabinets interconnected by their Front and Rear links as described in the previous section ⇒ Chapter 3.17.2 "E7812 Touring cart XSL-SUB" on page 28 and in position and the load beam has been already attached to the flying frame as described in the previous section ⇒ Chapter 5.1.1 "Attaching the Load beam to the Flying frame" on page 31, proceed as follows:

1. Attaching the flying frame

1. Extend the Front links of the uppermost SUB cabinet on both sides.
2. Lower the frame onto the SUB cabinet until the Front links fit into the slots at the front of the frame.
3. Reinsert the Locking pins of the Front links on both sides.
4. On the rear rigging strand, release both Locking pins.
5. Fold the Rear link into the rigging strand and reinsert the Locking pins.

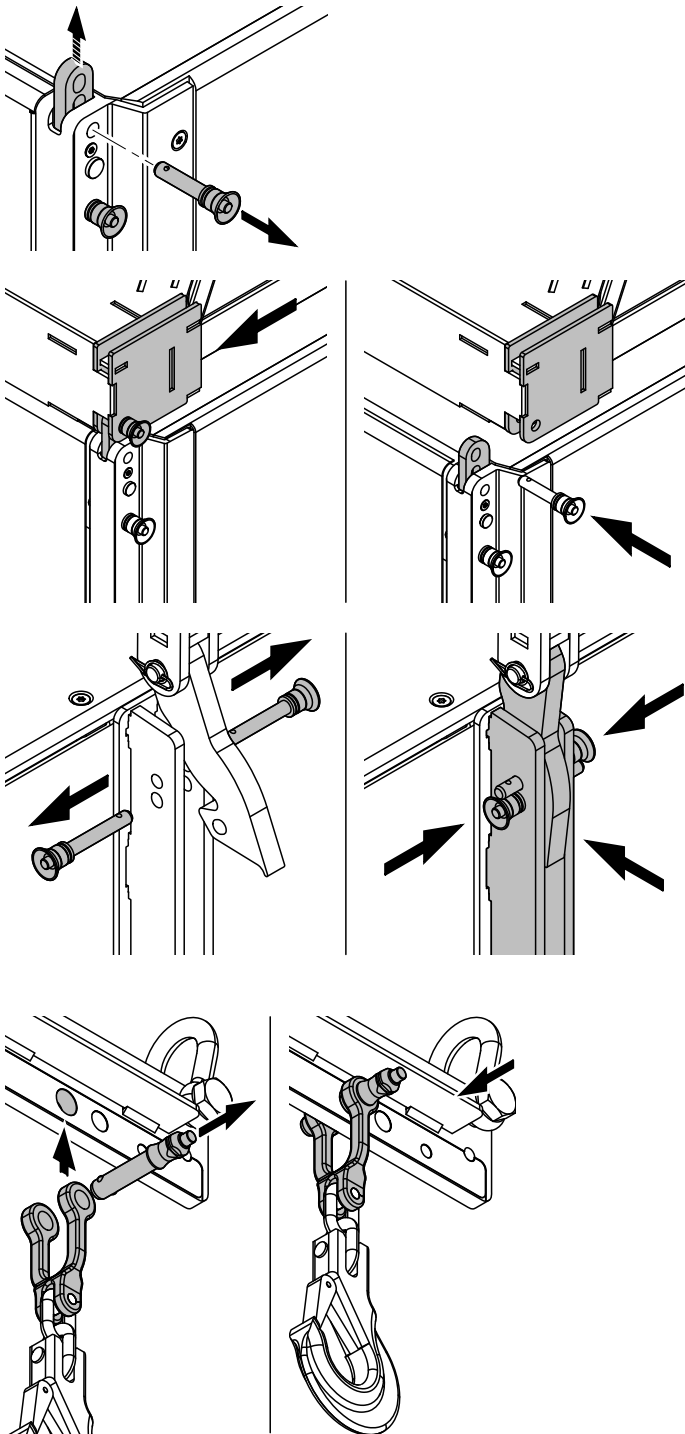

2. Attaching the cable pick (Z5713)

1. Release the Locking pin of the coupling shackle.
2. Attach the coupling shackle to the dedicated hole position at the rear end of the load beam.
3. Reinsert the Locking pin and ensure the pin is fully inserted and locked.
4. Set suitable lengths of the individual loudspeaker cables, and attach split sets when applicable and connect the cables subsequently during the entire setup procedure.

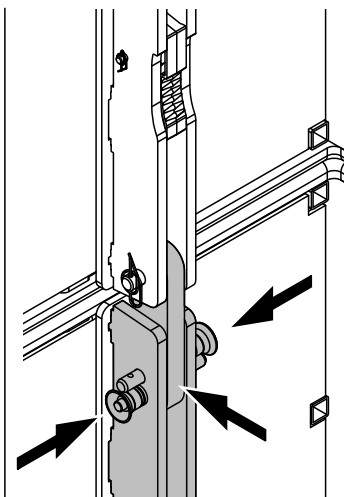
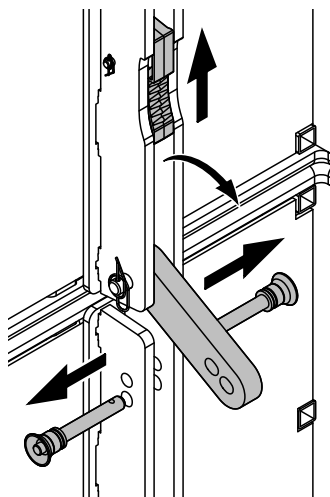
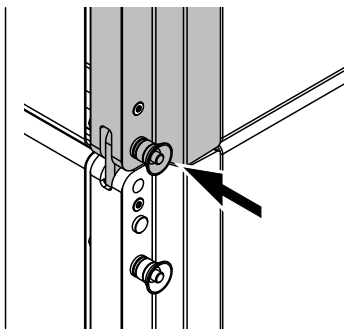
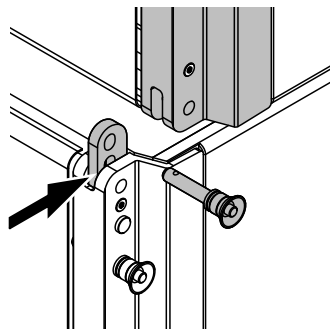
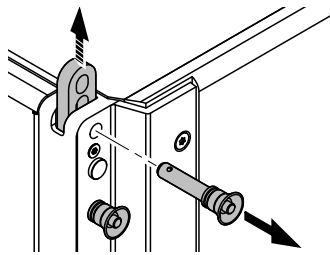

3. Attaching the next SUB assembly

1. Lift the assembly out of the touring cart to position the next assembly below and put the cart aside.
2. Position the next touring cart below and extend the Front links of the uppermost SUB cabinet on both sides.
3. Lower the array onto the cabinet until the Front links of the bottom cabinet fit into the slots of the upper cabinet.
4. Insert the Locking pins of the cabinet's Front links on both sides.
5. On the rear rigging strand, release the Locking pins of both cabinets.
6. Fold out the Rear link of the upper cabinet.
7. Reinsert the Locking pin on the upper cabinet.
8. Fold the Rear link into the rigging strand of the bottom cabinet.
9. Reinsert the two Locking pins on the bottom cabinet.

To add further cabinets, proceed in the same manner until the assembly is completed.

4. Check the assembly

Before hoisting the array to its operating position, recheck the actual status of the entire assembly according to the checklist given in ⇒ Chapter 12 "Safety and system checks" on page 57.

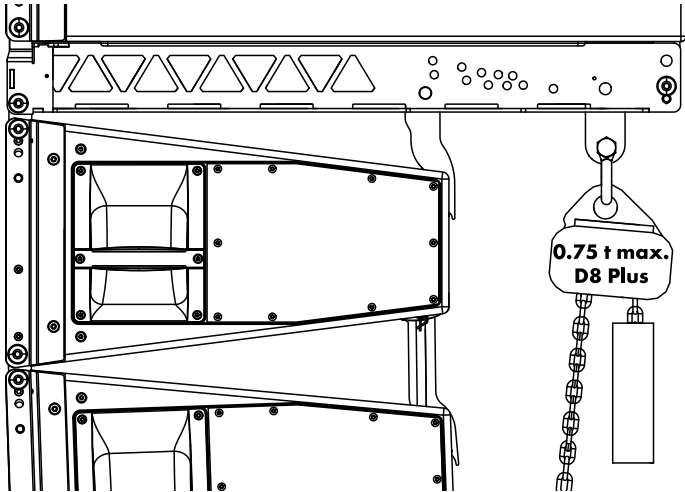
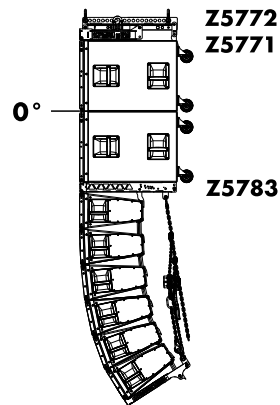

10.1 Remarks

NOTICE!

- For a mixed array setup, the Z5771 XSL Flying frame together with the Z5772 XSL Load beam must always be used as a suspension device. The Z5783 XSL-SUB Adapter frame is required in addition.
- Observe the maximum total system weight of 1000 kg (2200 lb) – SWL including all rigging components.
- The SUB cabinets must always be interconnected with 0° splay. Please also refer to ⇒ Chapter 3.16 “Cabinet rigging mechanism” on page 23.

10.1.1 Rigging modes

In connection with the adapter frame, the TOP cabinets underneath the SUB cabinets can also be set up in either Compression or Tension mode.



WARNING!

Potential risk of personal injury and/or damage to material.

When using a motor hoist instead of the lever hoist, observe the following:

- The maximum permitted compression force is **750 kg (0.75 t/7.5 kN)**.
The hoist overload clutch must be correspondingly adjusted.
- The motor hoist must be equipped with two independent brakes (according to the German **D8 Plus** standard).
- Observe your local legal requirements and Rules for the Prevention of Accidents (RPA).

10.2 Order of assembly

The assembly of a mixed array configuration is divided into the following three main procedures:

1. Suspending the desired number of SUB cabinets.
2. Attaching the adapter frame.
3. Attaching the TOP cabinets.

10.2.1 Suspending the desired number of SUB cabinets

The suspension and assembly of the SUB cabinets is similar to the suspension and assembly of a pure SUB column, as described in ⇒ Chapter 9 “SUB columns” on page 45.

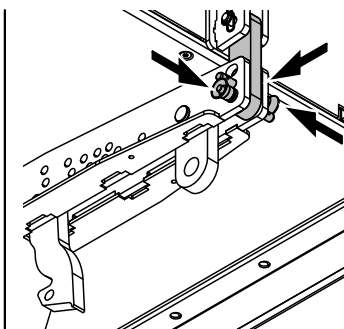
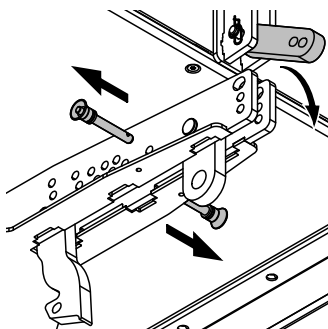
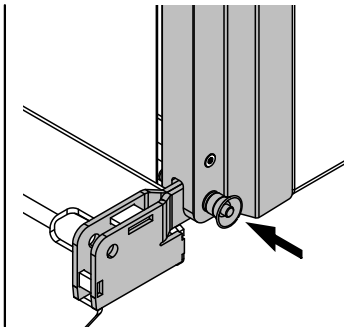
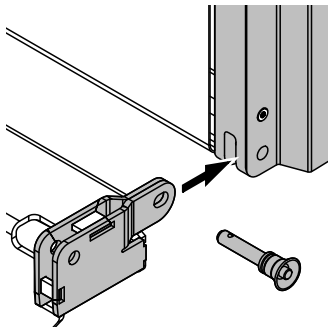
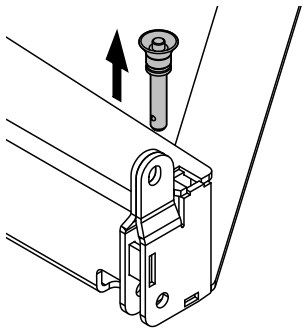

10.2.2 Attaching the adapter frame

1. Lift the SUB assembly to a suitable working height.
2. At the front of the adapter frame, release the Locking pins from their park position on both sides.
3. Attach the adapter frame to the SUB cabinet until the front supports of the frame fit into the slots on the front rigging strands of the cabinet.
4. Reinsert the Locking pins on both sides.
5. At the rear of the adapter frame, release the two Locking pins holding the Splay link and the Compression link in their park position (⇒ P).
 - ↳ The Splay link and the Compression link will fold out.
6. On the rear rigging strand of the last SUB cabinet, release the Rear link from its park position.
7. Insert the link into the slot of the adapter frame.
8. Reinsert both Locking pins to the Rear link slot.

10.2.3 Attaching the TOP cabinets

The attachment of the TOP cabinets (Touring cart assemblies) is similar to the assembly of a pure TOP column, as described in ⇒ Chapter 6 "Compression mode setup" on page 34 or ⇒ Chapter 7 "Tension mode setup" on page 40.

However, to connect the first TOP assembly to the adapter frame, proceed as follows:

1. Lift the current assembly to a suitable working height.
2. Position the first TOP assembly and extend the Front links of the uppermost cabinet.

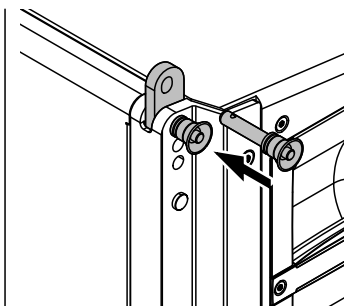
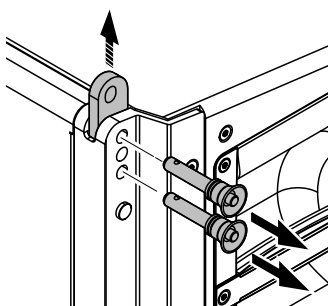

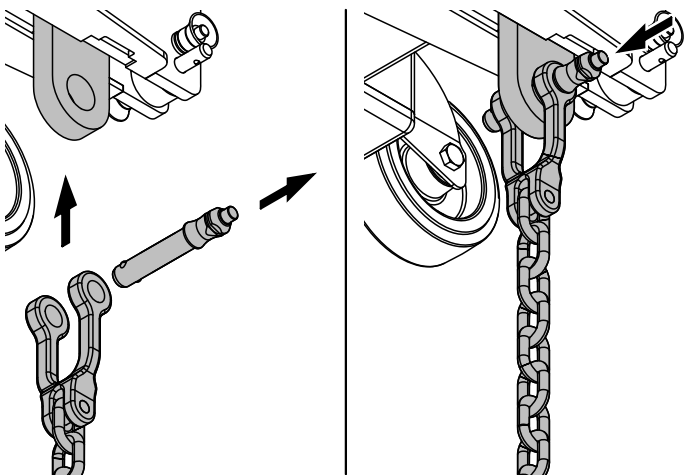
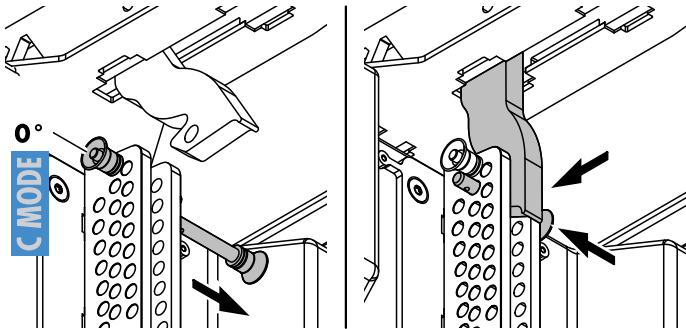
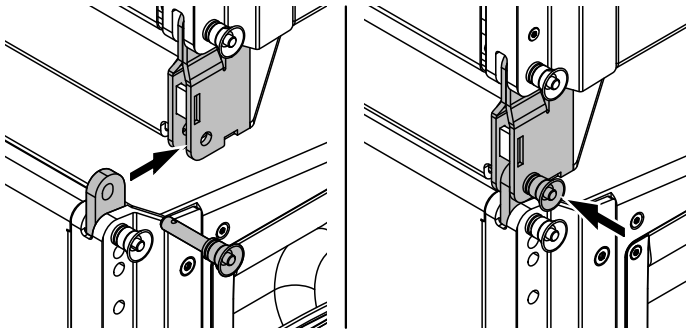

3. Lower the array until the Front links of the top cabinet in the cart fit into the slots at the front of the adapter frame.
4. Insert and lock the second Locking pins of the cabinet's Front links on both sides.
5. On the rear rigging strand, release Locking pin **[2]** and check Locking pin **[1]** is set to 0° (\Rightarrow Red labeled holes **C MODE**).
6. Slightly lower the array and fold the Splay link into the rigging strand.
7. Slightly lift the array until the Splay link has engaged into the preset Locking pin **[1]**.
8. Insert and lock Locking pin **[2]** (Safety pin) to secure the Splay link in place.

Attaching the compression chain

When the TOP cabinets are to be set up in Compression mode, we recommend you at this point of the procedure to attach the compression chain as follows:

1. Release the Locking pin of the coupling shackle.
2. Attach the coupling shackle to the compression pickpoint of the adapter frame.
3. Reinsert the Locking pin and ensure the pin is fully inserted and locked.

To complete the assembly, please follow the further setup procedures, as described in \Rightarrow Chapter 6 "Compression mode setup" on page 34 or \Rightarrow Chapter 7 "Tension mode setup" on page 40 depending on what setup mode is desired.



WARNING!

Potential risk of personal injury and/or damage to material!

Always secure ground stacked setups against movement and possible tipping over.

Observe the maximum number of cabinets permitted.

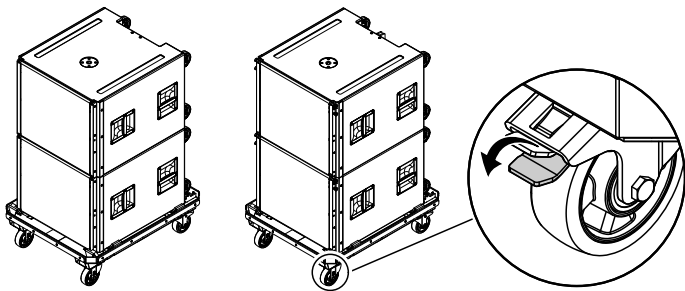

11.1 XSL-SUB/XSL-GSUB ground stack

Limitations

A maximum of two SUB cabinets together with the E7812 Touring cart serving as ground support are allowed to be set up as ground stack.

Setup procedure

With the touring cart serving as ground support, simply place the cart in position and lock all wheel brakes.

11.2 Mixed ground stack setup

11.2.1 XSL-SUB Adapter frame

For mixed ground stack setups, the Z5783 XSL-SUB Adapter frame is required in addition.

Limitations

A combination of a maximum of 4 x TOP on top of 2 x SUB cabinets is allowed to be set up as mixed ground stack.

Splay link of the adapter frame

For this type of setup, the Splay link of the adapter frame must be attached to the STACKING POSITION.

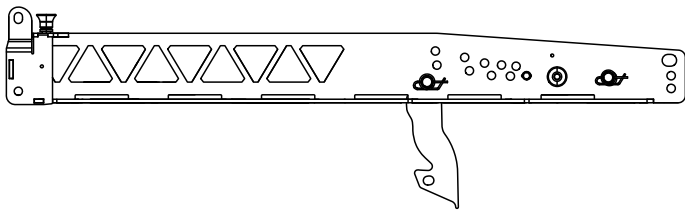

Splay link of the frame in FLYING POSITION (default)

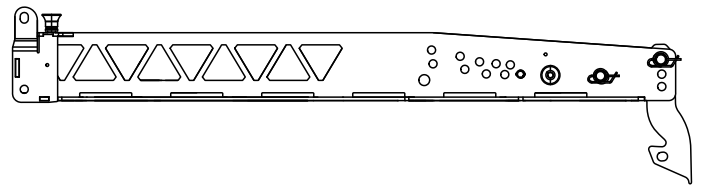

Splay link of the frame in STACKING POSITION

To change the Splay link position, proceed as follows:

1. Release the two Locking pins holding the Splay link and the Compression link in their park position (⇒ **P**).
↳ The Splay link and the Compression link will fold out.
2. Unlock the ring cotter of the Splay link fixing bolt.
3. Remove the fixing bolt and take off the link.

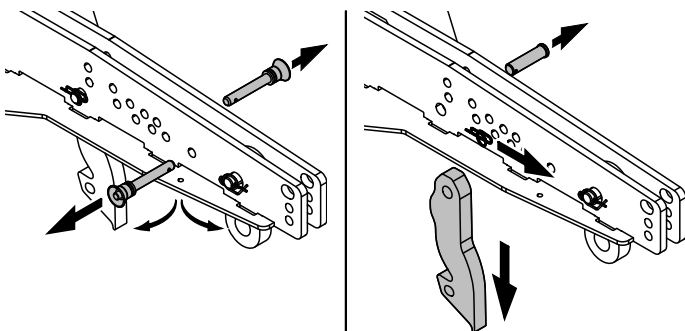

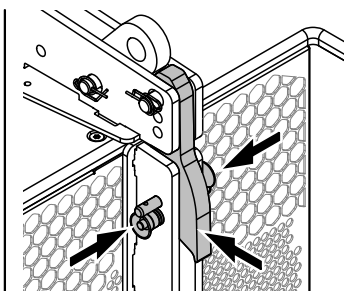
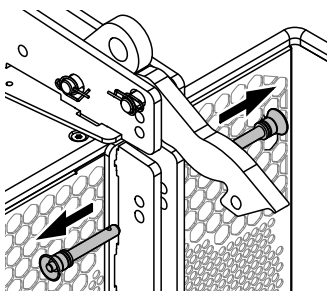
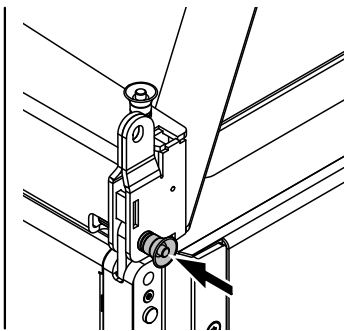
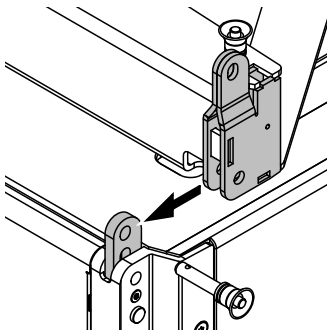
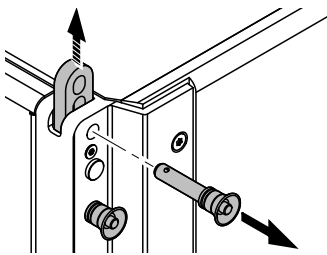
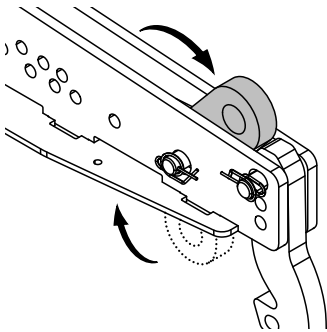
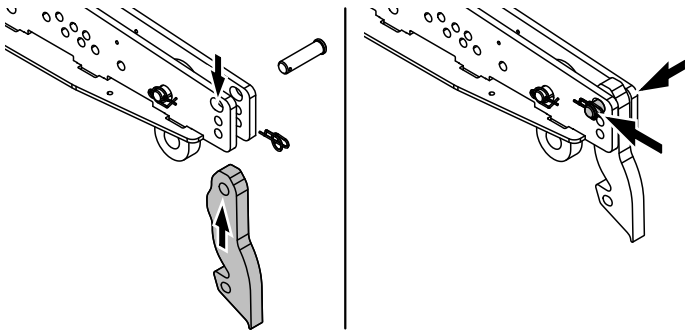

4. Attach the Splay link to the STACKING POSITION hole.
5. Insert the fixing bolt.
6. Secure the fixing bolt using the ring cotter and ensure the ring cotter is properly fitted and locked.

7. Finally fold the Compression link into its park position (⇒ STACKING MODE position).

11.2.2 Stack assembly

Attaching the adapter frame

Provided the SUB cabinets are already stacked in position, proceed as follows:

1. Extend the Front links of the uppermost SUB cabinet on both sides.

2. Attach the adapter frame to the SUB cabinet until the the Front links of the cabinet fit into the slots of the frame.
3. Reinsert the Locking pins of the Front links on both sides.

4. On the rear rigging strand of the SUB cabinet, release both Locking pins.
5. Fold the frame's Splay link into the rigging strand and reinsert the Locking pins.

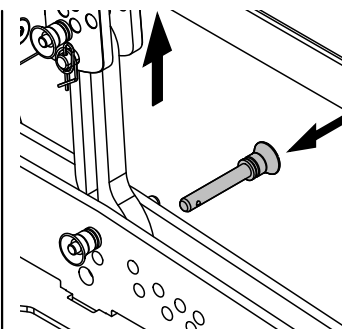
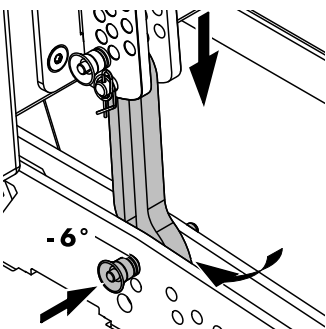
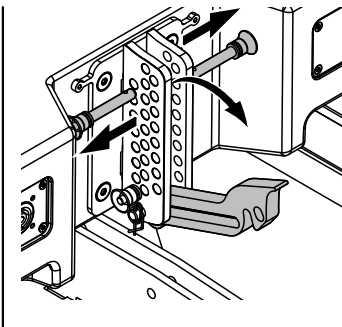
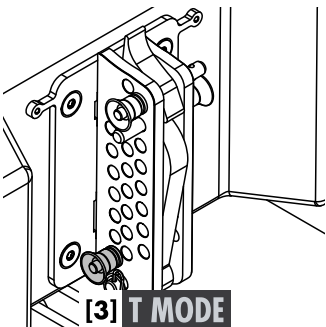
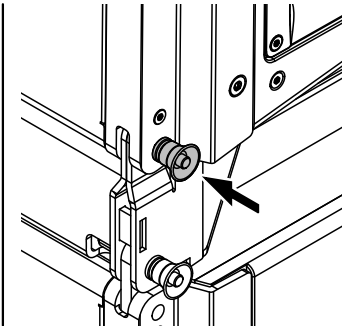
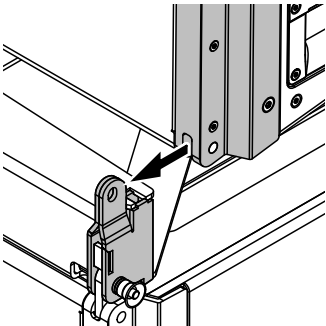
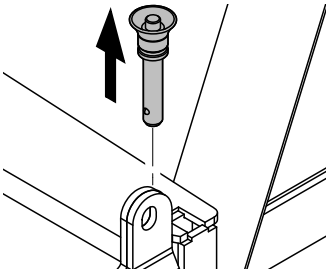
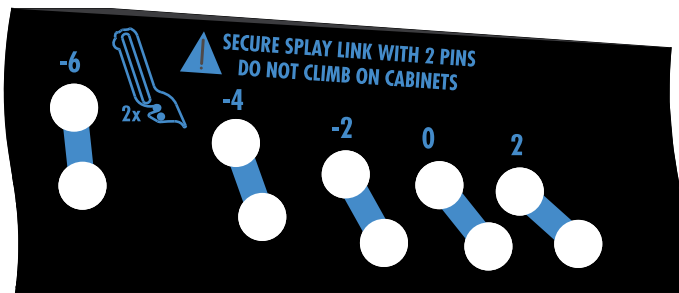

First cabinet to frame - Instruction label

The center Splay link slot of the adapter frame provides a dedicated hole grid to allow the first cabinet to be set to tilt angles from -6° to 2° (downtilt/uptilt) in 2° increments.

To attach the first cabinet to the frame, proceed as follows:

The required Locking pins are stored in their park position on both sides of the frame behind the respective front supports.

1. Take off the Locking pins from their park position.
2. Attach the first cabinet to the front supports of the frame and reinsert the Locking pins on both sides.
3. On the rear rigging strand of the cabinet, first ensure Locking pin **[3]** is inserted in the Tension mode hole at the bottom of the rigging strand (\Rightarrow Red labeled hole **T MODE**).
4. Release the two Locking pins (pin **[1]** and **[2]**) and fold out the Splay link of the cabinet.
5. At the center Splay link slot of the frame, set the desired tilt angle (e.g. -6° hole) using one of the Locking pins previously used to store the frame's Splay and Compression links in their park position.
6. Lower the cabinet and insert the Splay link into the slot.
7. Raise the back of the cabinet until the Splay link has engaged and insert the second Locking pin (\Rightarrow Safety pin).

Adding further cabinets

To add further cabinets, proceed as follows (⇒ Tension mode rigging):

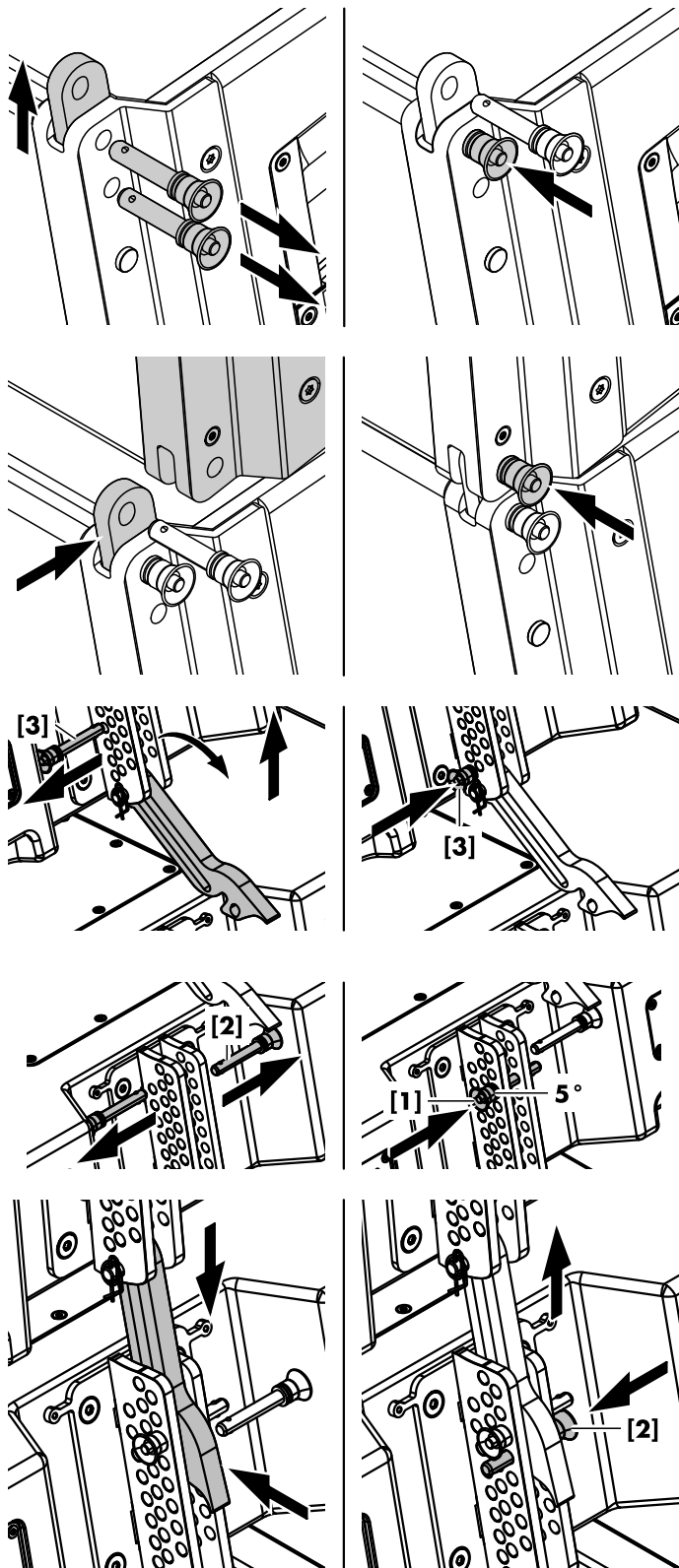

1. Extend the Front links of the first cabinet on both sides.
 - ↳ The Front links are spring loaded and therefore extend automatically as soon as the Locking pins are released and pulled out.
2. Place the next cabinet onto the first cabinet until the Front links fit into the slots of the cabinet.
3. Insert and lock the second Locking pins of the cabinet's Front links on both sides.
4. Slightly lift the back of the upper cabinet and release the Locking pin **[3]** holding the Splay link in its park position.
5. Fold down the Splay link and insert Locking pin **[3]** to the Tension mode hole at the bottom of the rigging strand (⇒ Red labeled hole **T MODE**).
6. On the bottom cabinet, release both Locking pins **[2]**.
7. Use Locking pin **[1]** to set the desired splay angle (e.g. 5°) on the center or outer hole grid of the bottom cabinet.
8. Lower the upper cabinet and insert the Splay link into the rear rigging strand of the bottom cabinet.
9. Raise the back of the upper cabinet until the Splay link has engaged and reinsert the second Locking pin **[2]** (Safety pin).

To add further cabinets, proceed in the same manner until the assembly is completed.

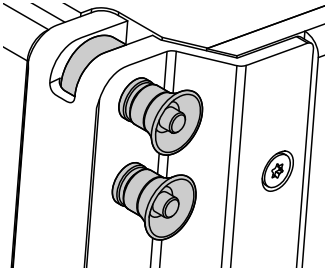

Front links of the last (uppermost) cabinet

NOTICE!

Potential risk of damage to the rigging components.

To avoid any damage to the Front links of the uppermost cabinet of the ground stack, ensure these Front links are kept in their park positions on both sides.

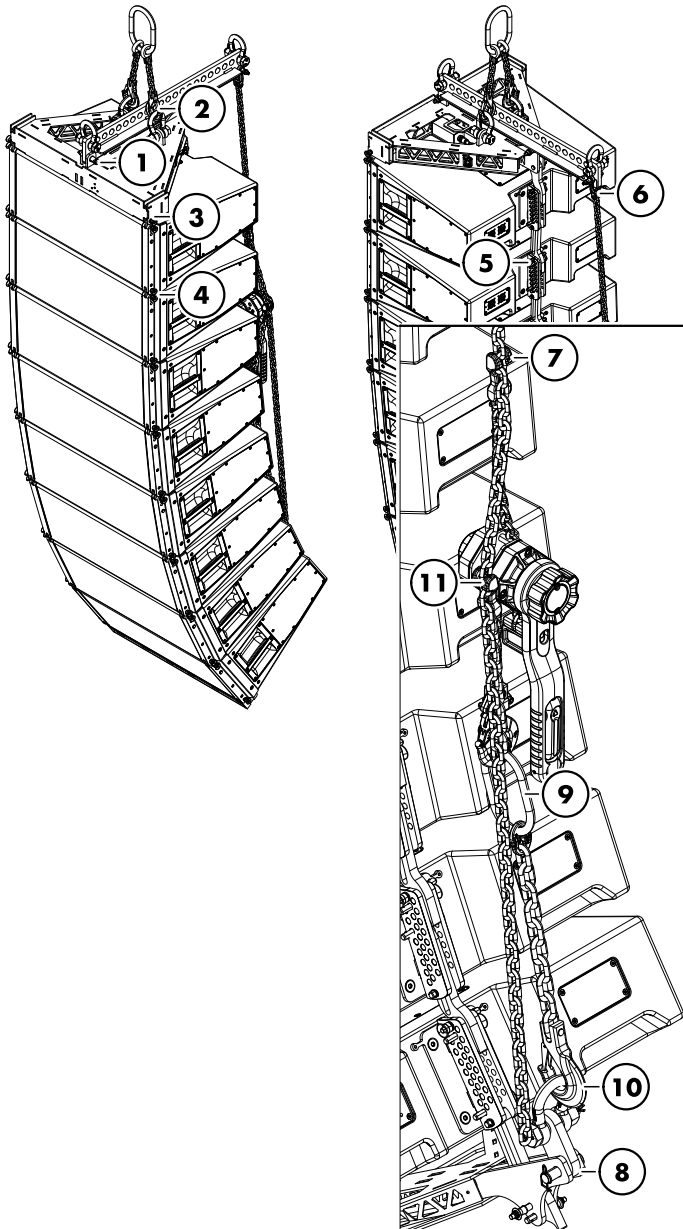

Before hoisting the array to its operating position, recheck the actual status of the assembly. When applicable, the same safety and system checks also apply to ground stack assemblies.

12.1 Mechanical setup

General

Be aware that any object or tool left on the top of the array during setup may fall when the array is operated. Always check that no tools or other objects are left on the array before final hoisting.

1. Check the attachment of the load beam to the flying frame and ensure all Locking pins are fully inserted and locked.
2. Check the attachment of the secondary safety device at the flying frame (refer to ⇒ Chapter 3.15 "Secondary safety" on page 23).
3. Check the attachment of the flying frame to the cabinets and ensure all Locking pins are fully inserted and locked.
4. Check the attachment of all Front links on both sides of the cabinets and ensure all Locking pins are fully inserted and locked.
5. Check the splay angles and the attachment of the Splay/Rear links at the rear of the cabinets and ensure all Locking pins are fully inserted and locked.

In Compression mode

6. Check the attachment of the compression chain's coupling shackle to the load beam and ensure the Locking pin is fully inserted and locked.
7. Check the position and attachment of the crank lever hoist's grab link to the compression chain.
8. Check the attachment of the compression frame and ensure all Locking pins are fully inserted and locked.
9. Check the attachment of the lever hoist to the O-ring of the compression frame master link and ensure the safety latch of the hook is closed.
10. Check the attachment of the compression frame master link to the shackle of the compression frame and ensure the safety latch of the hook is closed.
11. Ensure the grab link of the second chain leg of the compression frame master link is properly attached to the compression chain.

12.2 Wiring

- If the amplifiers are already wired and powered on, use their System check functions or channel mute switches and a test signal to check the correct operation and routing of all channels and cabinets.
- Alternatively check the wiring using the Array verification function in R1.

13.1 Hoisting the array



WARNING!

Potential risk of personal injury and/or damage to material!

Always ensure that each of the hoists is able to carry the total weight of the array.

When hoisting the array, unpredictable dynamic forces as well as swinging of the array must be taken into account. This may lead to personal injury and/or damage to the rigging components and loudspeaker cabinets.

Ensure there is nobody directly underneath or in the vicinity of the load who is not involved in the setup.

When all the mechanical adjustments, safety and system checks have been made, the array can be hoisted up to its operating position.

When hoisting the array, ensure that the loudspeaker cables do not get caught anywhere. The cables can be strapped together with the motor cables to form a loom while the system is hoisted.

The chain hoist motors must raise the system slowly and evenly so that it does not swing or move from side to side during hoisting.

13.2 Aiming the array

In connection with the Z5711 ArraySight sender unit (laser inclinometer), the horizontal and vertical aiming of the array can be sufficiently and easily adjusted.



CAUTION!

Laser beam

Potential risk of personal injury.

The high brightness laser of the d&b ArraySight sender unit requires additional safety considerations.

1. Take precautions to prevent anyone from looking directly into the laser beam.
2. Wear appropriate eye protection.
3. When making adjustments to the array with motor hoists, watch the hoist - **not** the meter unit!
4. Check the measurement only when you are satisfied that the hoist has finished moving safely.
5. However, the chain hoist motors must raise slowly and evenly.

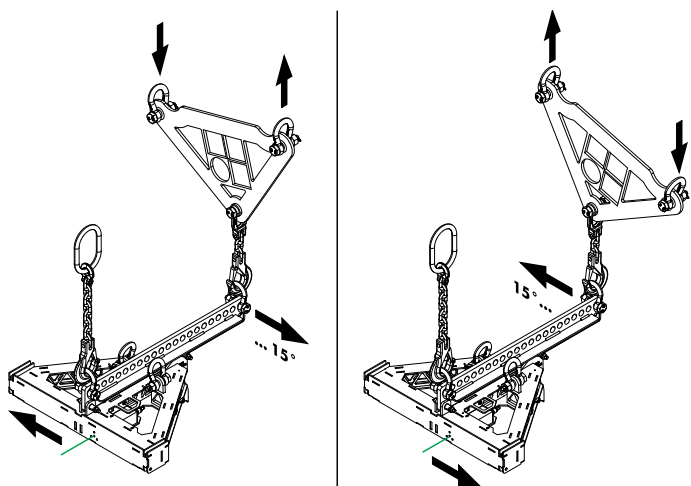

13.2.1 Horizontal aiming

In connection with the Z5707 SL Aiming plate the horizontal aiming of the array can be sufficiently and easily adjusted.

Note: To prevent the array from heavy movements, raise one hoist while lowering the other.

However, the chain hoist motors must be operated slowly and evenly.

With a chain hoist distance of minimum 0.6 m (2 ft), preferably approx 1 m (3 ft), the SL Aiming plate provides a horizontal angle range of $\pm 15^\circ$ (first and last pick holes of the load beam used).

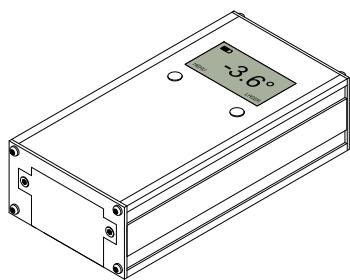
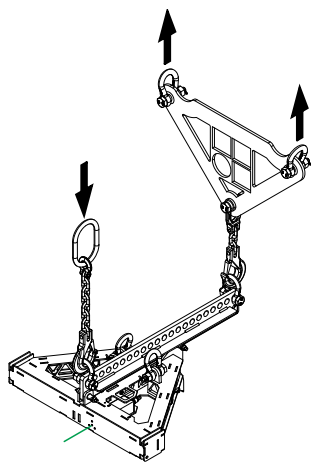

13.2.2 Vertical aiming

Application example

To take an example: ArrayCalc indicates a frame angle of -3.6° from vertical.

1. Using ArraySight to measure this angle, you raise the first array to its operating height and then check the meter unit screen.
2. The figures displayed settle as the meter compensates for the swing of the array. If the settled display shows $+0.5^\circ$, you then use the hoists to lift the rear or lower the front of the array. Make small adjustments and allow the meter unit to calculate the new angle. Continue to make adjustments until you achieve the angle of -3.6° .
3. Once the first array is complete, disconnect the meter unit from the first sender unit and reconnect it to the sender unit of the second array.
4. Repeat the procedure, starting with resetting the angle to zero for the second sender unit. Raise the second array, check the angle and adjust the angle as necessary.
5. If subsequent re-adjustment of the first array is required the meter unit can be re-connected to the first sender unit and the correct offset will be recalled.

13.3 Securing the array



WARNING!

Potential risk of personal injury and/or damage to material!

The secondary safety suspension must be independent of the primary suspension points and capable of carrying the total system weight.

The additional safety device must be mounted in a way that the array is caught by the safety device without any drop and swing in the event that the primary suspension fails.

When the array is in its final operating position, the secondary safety must be applied to its dedicated suspension point. Please also refer to ⇒ Chapter 3.15 "Secondary safety" on page 23.

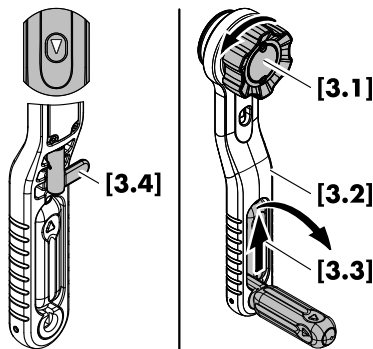
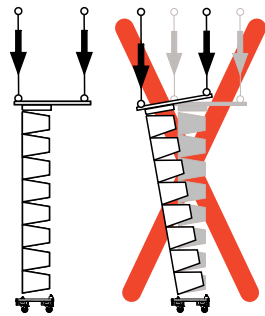

2. Detaching the compression set

Small hint: Apart from the compression frame, the compression set items can remain interconnected and stored. This simplifies further setups.

⇒ For this purpose, detach the compression grab link from the compression chain and the hook of the compression frame master link from the shackle of the compression frame.

3. Preparing the first four cabinets for loading

On all cabinets, change the position of Locking pin [3] from its splay angle hole back to the lowest hole of the bottom of the inner hole index (⇒ Red labeled hole  - **T MODE**).

4. Detaching the compression frame

Detach the compression frame in reverse order starting at the rear.

14.1 General

NOTICE!

The same safety instructions apply!

To dismantle any of the assemblies, follow the corresponding assembly and setup instructions in reverse order.

WARNING!
Potential risk of personal injury and/or damage to material!

In particular, make sure that when lowering and decompressing the array nobody is directly underneath or in the vicinity of the array.

When lowering the array, **avoid diagonal pull**. This could lead to the potential risk of the array tipping over towards the front.

14.2 Compression mode disassembly

1. Decompressing the array

1. Lower the array to a height of approx. 30 cm (1 ft) above ground.
2. Set the lever mode selector [3.4] to the lowering position (▽).
3. Release the hoist by turning the free chain knob [3.1] counterclockwise.
4. Fold out the crank [3.3].
5. Operate the crank lever [3.2] counterclockwise until the array is completely straight (decompressed).

5. Attaching the touring cart

1. Reattach the touring cart in reverse order starting at the front.
2. Lift the rear of the cart until the Splay link has engaged and reinsert the bottom locking pin.

6. Separating the first cabinet assembly

1. Slowly lower the array onto the ground until the Front and Splay links are free of load.
2. At the rear, release Locking pin [1] and [2] of the uppermost cabinet of the assembly and fold out the Splay link.
3. Reinsert the Locking pins to the same hole positions (⇒ Red labeled holes  - **C MODE**).
4. At the front, release the Locking pins of the Front links on both sides.
5. Lift the array and store the Front links.
6. For the remaining cabinet assemblies, proceed in the same manner.

7. Detaching the compression, safety chain and hoists

Once the last assembly is stored on the cart and lowered onto the ground, detach the compression and the safety chain and disconnect the hoists.

1. Disengage cabinet by cabinet

1. Lower the array to a height of approx. 30 cm (1 ft) above ground.
2. Attach the touring cart to the front of the lowest cabinet.
3. At the rear, release Locking pin **[2]** of the lowest cabinet.
4. Slightly lift the back of the cabinet and disengage the Splay link of the upper cabinet and keep on holding the cabinet.
5. At the center rear Splay link slot of the cart, release the bottom Locking pin.
6. Lower the cabinet until its Splay link fits into the slot.
7. Slightly lift the back of the cabinet until the Splay link has engaged and reinsert the bottom Locking pin.
8. Insert Locking pin **[1]** into the 0° hole at the top of the center hole index (⇒ Red labeled hole  - **C MODE**).

2. Disengaging cabinet by cabinet

1. On the next cabinet, release Locking pin **[2]**.
2. Slightly lift the back of the cabinet and disengage the Splay link.
3. Lower the cabinet until its Splay link fits into the rear rigging strand of the bottom cabinet.
4. Lift the back of the cabinet until its Splay link engaged to preset Locking pin **[1]** (0°) of the bottom cabinet.
5. Reinsert Locking pin **[2]** (Safety pin) of the bottom cabinet.
6. For the next two cabinets, proceed in the same manner.

8. Detaching and storing the load beam

1. Release the Locking pins of the flying frame.
2. Detach the load beam and reinsert the Locking pins of the flying frame.
3. Store the load beam in the dedicated slots of the touring cart.

14.3 Tension mode disassembly

In Tension mode, the derigging procedure follows the setup procedure in reverse order. That means the Splay links have to be disengaged manually cabinet by cabinet. Proceed as follows:

3. Separating the first cabinet assembly

1. Slowly lower the array onto the ground until the Front links are free of load.
2. Release the Locking pins of the Front links on both sides.
3. Lift the array and store the Front links.
4. For the remaining cabinet assemblies, proceed in the same manner.

4. Detaching the safety chain and hoists

Once the last assembly is stored on the cart and lowered onto the ground, detach the safety chain and disconnect the hoists.

5. Detaching and storing the load beam

1. Release the Locking pins of the flying frame.
2. Detach the load beam and reinsert the Locking pins of the flying frame.
3. Store the load beam in the dedicated slots of the touring cart.

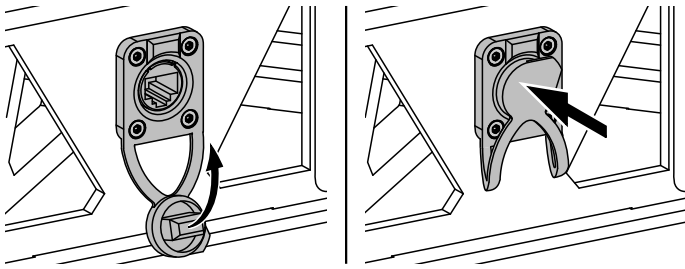

15.1 Transport / Storing

During transport ensure the rigging components are not stressed or damaged by mechanical forces.

Due to their surface treatment the rigging components are temporarily protected against moisture. However, ensure the components are in a dry state while stored or during transport.

15.2 etherCON connector socket protection

To prevent corrosion of the etherCON connector socket's spring contacts, always make sure to properly attach (close) the connector socket's dust cap during transport or when it is not in use.

15.3 Visual and functional inspection



WARNING!

Potential risk of personal injury and/or damage to material

To eliminate the potential risk of accident due to malfunctioning of a component, regularly inspect all system components.

Cabinet enclosure

- Visual inspection of all fitting plates for obvious damage (e.g. cracks or corrosion).
- Visual inspection of the rear rigging strand for obvious damage (e.g. cracks, deformation or corrosion) including all drilled holes of the component.
- Inspection of all fitting plates including front grills to ensure they are securely attached.
- Regularly lubricate the sockets using WD-40® or a similar product.

Front and Splay/Rear links

Visual inspection regarding deformation and damage (e.g. cracks and corrosion) including all drilled holes of the component.

Locking pins

- Visual inspection for deformation, cracks and corrosion of the component.
- Inspection for missing ball bearings and damage.
- Functional inspection of the release mechanism to ensure it operates properly.
- Regularly lubricate the Locking pins using WD-40® or a similar product.

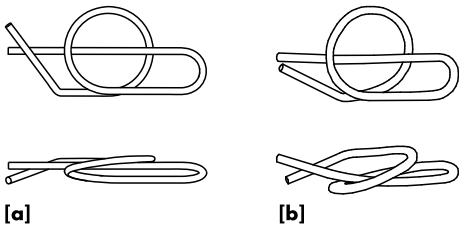
**Condition of the ring cotter****[a]:** Ring cotter OK**[b]:** Exchange the ring cotter**Ring cotters**

- Visual inspection for obvious damage and deformation.
- Functional test of the locking mechanism as described in ⇒ Chapter 3.13 “Ring cotters” on page 21.
If a ring cotter can no longer be properly fitted to the fixing bolt and locked, it must be exchanged.

XSL Flying frame and Compression frame

- Visual inspection regarding any indication of deformation and damage (e.g. cracks and corrosion) including all drilled holes of the component.
- Visual inspection regarding the attachment and securing of the shackles.
- Regularly check the flatness of the frames. For this purpose, position the frames on a flat surface and visually check the frames for deformation and/or torsion. For obvious deformation and/or torsion contact d&b audioteknik for further advice on how to proceed.

XSL Load beam

- Visual inspection regarding any indication of deformation and damage (e.g. cracks and corrosion) including all drilled holes of the component.
- Visual inspection regarding the attachment and securing of the shackles.
- Regularly check the flatness of the beam. For this purpose, position the beam on a flat surface and visually check the beam for deformation and/or torsion. For obvious deformation and/or torsion, contact d&b audioteknik for further advice on how to proceed.

Z5707 SL Aiming plate

- Visual inspection regarding any indication of deformation and damage (e.g. cracks and corrosion) including all drilled holes of the component.
- Visual inspection regarding the attachment and securing of the shackles, coupling shackle and chain.

XSL Compression set components**Z5775 Safety chainset 2 t****Z5776 Hoist connector chain 2 t**

Inspection according to the appropriate regulations for lifting devices (EN 818-6:2000).

- Regularly inspect within a 12 months period.
- Regularly inspect for cracks within a 36 months period.



16.1 Conformity of rigging components

This declaration applies to:

d&b XSL loudspeaker cabinets

(with integrated rigging components.)

- Z0770 XSL8
- Z0772 XSL12
- Z0774 XSL-SUB
- Z0775 XSL-GSUB

d&b XSL rigging components

(including all additional components)

- Z5771 XSL Flying frame
- Z5772 XSL Load beam
- Z5773 XSL Compression set
 - Including:
 - Z5789 XSL Compression chain 1.5 t.
 - B2467.074 XSL Compression frame master link
 - B2467.072 XSL Crank lever hoist 750 kg
- Z5774 XSL Compression frame
- Z5775 Safety chainset 2 t.
- Z5776 Hoist connector chain 2 t.
- Z5783 XSL-SUB Adapter frame
- Z5792 XSL Pullback frame

by d&b audiotechnik GmbH & Co. KG.

All product variants are included, provided they correspond to the original technical version and have not been subject to any later design or electromechanical modifications.

We herewith declare that said products are in conformity with the provisions of the respective directives including all applicable amendments.

Detailed and applicable declarations are available on request and can be ordered from d&b or downloaded from the d&b website at www.dbaudio.com.

WEEE-Reg.-Nr. DE: 13421928

16.2 Disposal

When out of use the rigging components must be disposed of in accordance with the national environmental regulations.

Ensure that damaged rigging components are disposed of in a way that they cannot be used again.

